

ROOM SHAPE AND SIZE ESTIMATION USING DIRECTIONAL IMPULSE RESPONSE MEASUREMENTS

PACS: 43.55 Br

Gunel, Banu

Sonic Arts Research Centre (SARC)
School of Computer Science
Queen's University Belfast
Belfast, BT7 1NN, UK
Tel: ++44 (0) 28 9027 4761
Fax: ++44 (0) 28 9027 4828
E-mail: b.gunel@qub.ac.uk

ABSTRACT

Impulse response of a room carries abstract information on the size and shape of that room. Acoustics research has focused on obtaining reflectograms from these physical characteristics using acoustical modelling techniques. However, estimation of the physical structure is also possible by analyzing the impulse responses for early reflections, echo amplitudes, arrival times and reverberation time. This paper proposes a new method to estimate the physical structure of a room using the features of *directional impulse response* (DIR) measurements obtained by applying the MLS-technique with a directional loudspeaker and a soundfield microphone. The results for 4 rooms were also displayed.

INTRODUCTION

The acoustical behaviour of a room is defined by the impulse response (IR), which is strongly related to the room's physical structure. This relationship is often exploited to predict the IR of a room from the room's shape, size and surface materials using methods like ray tracing, image source or hybrid methods [1][2].

However, it is also possible to estimate the physical structure of a room using this relationship. It has been shown before that the reverberation carries information on the characteristics of the space and provides information on the room size [3]. The reflections up to 80ms are called early reflections and were previously found to be useful for the human perception of room size [4][5]. The usage of echoes for distance estimation forms the basis of radar and sonar applications [6][7]. The reverberation time also depends on the volume, surface area and the surface materials [8].

Specifically, the echo amplitudes, arrival times and the reverberation time can be listed as the features of the IRs that convey information on the physical structure of the room. The accuracy of the information these features provide can be increased by the directional impulse responses (DIRs), which are measured by a directional loudspeaker and a soundfield microphone.

The method of obtaining DIRs based on the MLS-technique will be explained in the first section. The analysis carried on these DIRs to estimate the physical structure a room and the effect of using directional loudspeaker on the reverberation time will be explained in following section. The results of the tests for 4 rooms with varying shapes and sizes are displayed next.

DIRECTIONAL IMPULSE RESPONSE (DIR) METHOD

Obtaining the impulse response of a room is possible by using several methods such as exciting the room with the impulsive sources like balloons or pistol shots, or more robust methods like time-delay spectrometry (TDS) and maximum length sequence (MLS) techniques [9]. MLS-technique is preferred over the impulsive source methods in terms of its robustness and over the swept-sine technique in terms of the higher time resolution it provides [10].

MLS-technique is based on the usage a maximum-length sequence, which has a flat magnitude spectrum like a single impulse. Therefore, the impulse response of a room can be calculated by cross-correlation of the MLS stimuli and the recording of the sound within the room during the excitation by the same stimuli [11].

The ISO 3382 standard states that the measurement of the room impulse responses should employ an omnidirectional loudspeaker and an omnidirectional microphone [12]. This ensures the uniform excitation of the room and recording of the room response. However, for the purpose of modelling the room physical structure, a directional loudspeaker and a directional microphone can be employed. Therefore the measurement focuses on a region of the room enabling more accurate detection of the echo amplitudes and arrival times. The directional loudspeaker used for this purpose should have improved directivity, which causes more direct sound and less reverberant sound to be delivered. On-axis response of the loudspeaker should be as flat as possible to prevent distortion.

A soundfield microphone is required for recordings. Since the analysis requires the Bformat signals recorded on a digital audio tape (DAT) without any processing, a proper combination of 3 figure-of-eight and 1 omnidirectional microphone can also be used to obtain the W, X, Y and Z signals [13]. The generation of the cardioid patterns from these signals can be carried out using the MATLAB program after transferring the contents of the DAT to a PC. By the addition of the omni signal W and X, Y, Z or their combinations, cardioid patterns looking at different directions can be synthesized. The cross-correlation of these cardioid recordings and the MLS sequence yields the DIRs.

Loudspeaker and Microphone Locations for DIR Measurements

The number of the measurement locations is a compromise between the details of the room structure and the amount of the data analysed. The locations of the loudspeaker and the microphone can be chosen relative to each other, but not relative to the room surfaces, since it is assumed that no prior information about the room size is available. For convenience, the locations of the microphone are chosen on a circle of 1m radius with equal intervals of angle and the loudspeaker is placed at the centre of this circle, which was arbitrarily chosen. The height of the loudspeaker and the microphone was fixed at 1.5m and it was made sure that the front of the loudspeaker and the microphone look at each other for all the measurement positions. Therefore the echoes from the walls arrive at the soundfield microphone always behind the microphone (see Fig. 1).

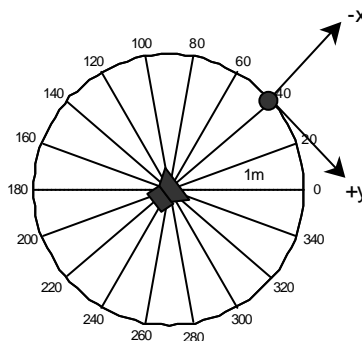

Fig. 1.- Loudspeaker and microphone locations for 18 points with 20° intervals

Modification to this placement is possible as long as the distance of the microphone from the loudspeaker and the angle between the microphone positions are known.

ANALYSIS OF THE DIRECTIONAL IMPULSE RESPONSES (DIRs)

The physical structure of the room can be drawn by determining the wall sizes, shapes, the number of walls and the height of the room. If the directivity of the loudspeaker is known, the reverberation times calculated theoretically and measured experimentally can be compared to validate the results.

Sweeping Cardioid Patterns

Since the reflection angle from the wall is not known, the arrival angle of the sound waves to the microphone is found by sweeping cardioid patterns for different angles. The cardioids sweep the horizontal plane from -60° to $+60^\circ$ with 5° intervals. Therefore, for each microphone position, 25 directional impulse responses are generated. The polar equation involving the B-format signals and the sweeping angle used for generating cardioid patterns is shown below:

$$C = W - X \cos I + Y \sin I = 1 - (\cos q \cos I + \sin q \sin I), \quad I = -60, -55, \dots, 60$$

Echo Detection and Distance Computation

The impulse responses for each swept angle and position are normalized and shifted so that the direct sound has 0dB amplitude and starts at $t=0$ sec for each cases.

The algorithm for detecting the first echo depends on finding the signals with the maximum amplitude after the direct sound and a silence period. The arrival angle of the reflected sound, the arrival time of it and the amplitude can be found by comparing the echoes for different sweeping angles (see Fig. 2). This method works even if the microphone is placed at a distance less than the critical distance, which changes according to the room surface area, absorption coefficients and the directivity of the loudspeaker.

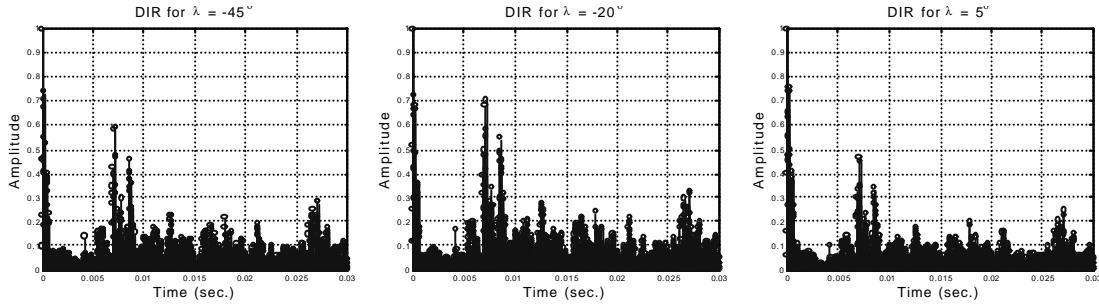

Fig. 2. - First 30ms of DIRs for the scanning angles $\lambda=-45, -20$ and 5 from left to right.

A table is obtained showing the echo arrival angle, λ , amplitude, A and time delay, t_d for each recording position at the end of this analysis. The distance, d that the sound travels from the loudspeaker to the wall and the wall to the microphone is calculated using the equation below:

$$d = 1m + t_d \times (331m/s + 0.6m/s \times T^\circ C)$$

The distance, d and the arrival angle, λ are used to find the distance, d' , using the formula below, whose lengthy derivation was skipped for convenience (see Fig. 3). The polar plot of the angle, β and distance, $(1+d')$ for each measurement point gives a model of the room shape.

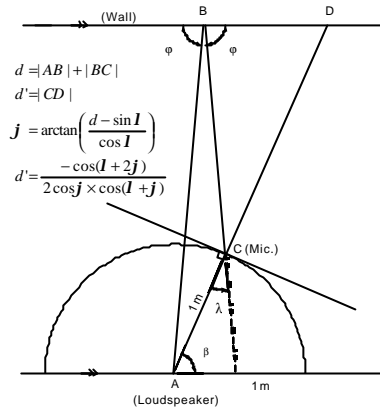

Fig. 3.- Calculation of the actual distances from the sweeping angle and the found distance

Finding the Number of Walls

The distance value, d' and the angle, β for each recording position can be used for estimating the number of walls. Clustering analysis computes the Euclidean distance between the vectors $[d_n' \cos(\beta_n) \sin(\beta_n)]$ for each recording position n . A tree is obtained by using these distances and the groups are made by cutting the tree slightly below the maximum inconsistency value. The number of groups gives the number of walls present in the room.

Finding the Room Height

Room height estimation uses the principle of sweeping cardioid angles, which employs W, X and Z signals. The height of the room ($h+1.5\text{m}$) can be found with the help of the distance, d and the sweep angle, λ (see Fig. 4).

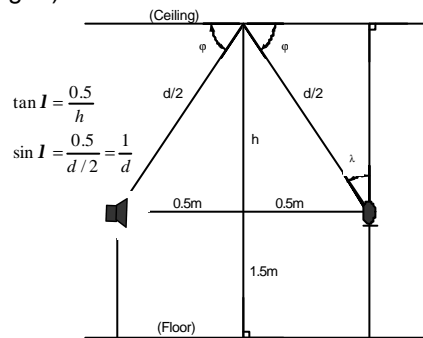

Fig. 4.- Calculation of the room height from the sweeping angle and the found distance

Comparison of the Theoretical and the Experimental Reverberation Times

To find the reverberation time, the impulse responses obtained from the omnidirectional W signal only, are filtered with octave band filters, designed as the 6th order Butterworth filters with $f_c=125$ to 4000. Next, the Schroeder integral is computed from these impulse response. The reverberation times, T30 obtained from the slope of this integral are always found to be much longer than the theoretical T30 values, computed using the Sabine equation:

$$RT = \frac{0.161 \times V}{Sa}$$

where V is the volume and Sa is the total absorption, in sabins. The difference between the theoretical and the experimental values is due to the directional loudspeaker used. The reverberation time is inversely proportional to the directivity of the loudspeaker. Therefore the reverberation times, which are computed with the omnidirectional loudspeaker should be divided by the directivity factor of the loudspeaker taking into account that this factor changes with frequency.

RESULTS

Directional Impulse Response (DIR) method described above was tested on 4 empty rooms with varying sizes and shapes. Rooms 1, 2 and 3 had carpet and room 4 had wood floor. The temperature of the rooms and the background noise levels (A weighting) during the measurements were recorded as 24°C, 21°C, 19°C, 17°C and 38dB, 33dB, 30dB and 34dB for rooms 1 to 4, respectively. The recordings were made using a Genelec 1031A loudspeaker, a soundfield microphone and a TASCAM DA-98 (16-bit) multichannel digital recorder. The MLS sequence was played from the first channel of the DAT and the B-format signals were recorded on the channels 5 to 8.

Polar Plots Showing the Size and Shape of the Rooms

The polar plots drawn after the cardioid sweeping, echo detection and distance computation are shown below together with the floor plans of the rooms (see Fig. 5). The mean absolute error of the estimated wall distances is 1.37m (%41), 0.6m (%26), 0.29m (%16) and 0.44m (%20) for rooms 1 to 4, respectively.

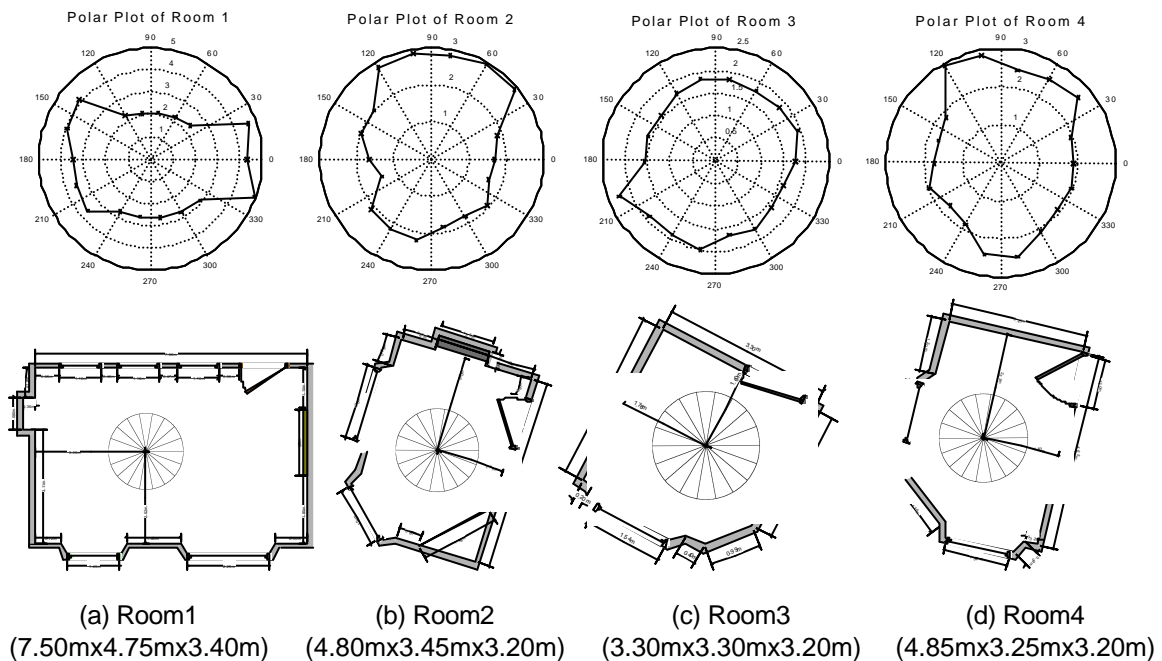

Fig. 5.- Polar plots and the floor plans of the rooms (not to scale)

An Example Result of the Analysis to Estimate the Number of Walls

Clustering analysis for room 1 yields the number of walls as 5 (see Fig. 5a) and groups them as [1,2,18] (right wall), [3,4,5,6,7] (up wall), [8,9] (the small place on the left wall), [10,11,12] (rest of the left wall) and [13,14,15,16,17] (down wall) (see Fig. 5a and 6).

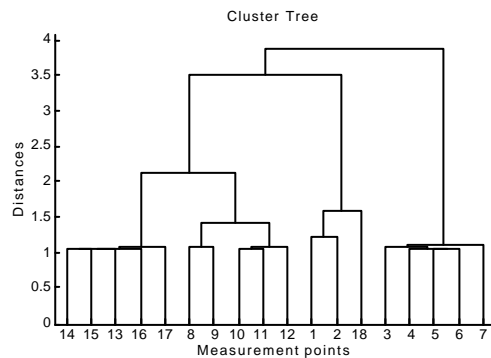

Fig. 6.- Cluster tree for room 1, showing the groups of measurement points

Calculated Room Heights

The calculated room heights were found to be significantly less than the actual values. The heights found are 3.12m, 2.70m, 2.75m, 2.99m for rooms 1 to 4, whose actual heights were 3.40 for room 1 and 3.20 for the remaining 3. The error can be reduced by making one more recording by turning the front of the loudspeaker to the ceiling with a small known angle.

Comparison of the Reverberation Times

The reverberation times of the rooms were computed using the Sabine's equation and the DIRs (see Fig. 7a and b). The solid line in these curves is for room 4, which has higher reverberation at high frequencies since that room's floor is not covered by carpet, which absorbs high frequencies. The measured reverberation times were higher than computed values because of the directivity of the loudspeaker. This directivity coefficient was found by dividing the theoretical reverberation times by the computed ones (see Fig. 7c). The directivity coefficients change with the frequency but keep almost constant for all the rooms.

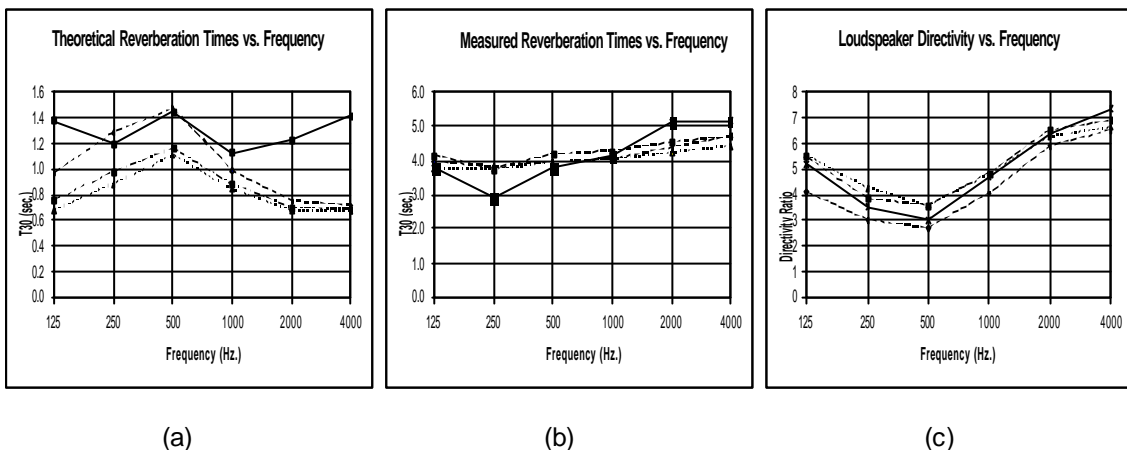

Fig.7.- (a),(b) Theoretical and measured reverberation times RT at 6 octave bands for 4 rooms, (c) The directivity of the loudspeaker calculated from the reverberation times.

CONCLUSIONS AND FUTURE WORK

A directional impulse response (DIR) method, which employs MLS sequences with a directional loudspeaker and a soundfield microphone, was proposed to estimate the room shape and size. The analysis of the data depends mainly on the sweeping cardioid patterns for the horizontal plane. Extra information about the room can be obtained by clustering analysis, vertical sweeping of the cardioids and reverberation time calculations at octave bands. The results show that the method works well for creating rough drawings of the room's top view but needs some corrections for height estimation.

The future work includes improving the method for more accurate height estimation and extending the analysis for determining the absorption coefficients from the echo amplitudes.

ACKNOWLEDGEMENTS

The author gratefully acknowledges Mr. Chris Corrigan for the technical support he provided during the measurements.

BIBLIOGRAPHICAL REFERENCES

- [1] J. H. Rindel, "The use of computer modelling in room acoustics", Journal of Vibroengineering, 2000 No. 3(4) pp. 41-72, International Conference Baltic-Acoustic (2000)

- [2] M. Vorlander, "Simulation of the transient and steady state sound propagation in rooms using a new combined ray-tracing/image source algorithm", *J. Acoust. Soc. Am.* 86, 172-178 (1989).
- [3] J.S. Bradley, G.A. Soulodre, "The influence of late arriving energy on spatial impression", *J. Acoustic. Soc. Am.*, 97, 2263-2271 (1995)
- [4] D. R. Begault, "3-D Sound for Virtual Reality and Multimedia", Academic Press, London, (1994)
- [5] B. G. Shinn-Cunningham, "Distance cues for the virtual auditory space", Proceedings of the IEEE-PCM, Sydney, Australia (2000)
- [6] R. O. Neilsen, "Sonar Signal Processing", Artech House, Boston (1985)
- [7] N. Levanon, "Radar Principles", Wiley, New York (1988)
- [8] L. L. Beranek, "Acoustics and the concert hall", *J. Acoust. Soc. Am.*, 57, pp. 1258-1262 (1975)
- [9] A. Farina, P. Fausti, "Acoustic Measurements in Opera Houses: Comparison Between Different Techniques and Equipment", *Journal of Sound and Vibration*, vol.232, no. 1, pp. 213-229 (2000).
- [10] F. A. Everest, "Master Handbook of Acoustics", 4th Edition, McGraw-Hill (2001)
- [11] M. R. Schroeder, "Integrated-impulse method measuring sound delay without using impulses", *J. Acoust. Soc. Am.*, 66(2), pp. 497-500 (1979)
- [12] ISO 3382, Acoustics – Measurement of the reverberation time of rooms with reference to other acoustical parameters
- [13] A. Farina, E. Ugolotti, "Software implementation of B-format encoding and decoding", Pre-prints of the 104th AES Convention, Amsterdam (1998)