



MADRID  
**inter.noise 2019**  
June 16 - 19

NOISE CONTROL FOR A BETTER ENVIRONMENT

## **Purely acoustics broadband phase shifter without electronics**

**Sakamoto, Shuichi<sup>1</sup>**

**Niigata University**

**Ikarashi 2-no-cho 8050, Nishi-ku, Niigata-city, Niigata-pref., 950-2181, Japan**

**Nakamura, Yuya<sup>2</sup>**

**Niigata University**

**Ii, Kohei<sup>3</sup>**

**Niigata University**

**Sugai, Taiga<sup>4</sup>**

**Niigata University**

### **ABSTRACT**

**In this study, we propose a purely acoustic broadband phase shifter that can be utilized for active noise control. In the proposed phase shifter, an opposite phase signal is automatically produced by exclusively using a purely acoustic-mechanical structure, without the moving components. Hence, the phase shifter does not require a power supply or control circuit. In active noise control, this approach eliminates the need for digital signal processing to generate an opposite phase signal. Because phase signal processing is not required, an adaptive signal can be produced using only on the frequency characteristics of the gain. In the small clearance, because of the boundary layer near the wall surface, the lower the frequency is, the smaller the sound velocity will be; the frequency characteristic of the sound velocity can be controlled by adjusting the width of the clearance. The frequency and phase relations were derived using equations such that an opposite phase is provided according to the frequency characteristic of the sound velocity over a broad frequency band.**

**Keywords:** ANC, Physical Phase Shifter, Sound Velocity

**I-INCE Classification of Subject Number:** 38, 74, 26

---

<sup>1</sup> [sakamoto@eng.niigata-u.ac.jp](mailto:sakamoto@eng.niigata-u.ac.jp)

<sup>2</sup> [f18b113f@gmail.com](mailto:f18b113f@gmail.com)

<sup>3</sup> [f17b085b@gmail.com](mailto:f17b085b@gmail.com)

<sup>4</sup> [stn12737.shikisama@gmail.com](mailto:stn12737.shikisama@gmail.com)

This study is patent pending.

## 1. INTRODUCTION

The side branch-type silencers and interference-type silencers are fabricated using main tubes and branch tubes. However, the silencer performance can only be obtained at specific frequencies. The interference-type silencers are considered to be a form of active noise control <sup>1</sup> in a primary one-dimensional duct even if its objective is to provide silencing over a wide frequency range using signal processing.

In this study, we propose a phase shifter that uses a pure acoustic-mechanical system, which does not rely on electronic circuits to produce reverse-phase sound waves over a wide range. This phase shifter exhibits the frequency characteristic of sound velocity using the clearances between two surfaces <sup>2</sup>. Further, the logical principles for the silencers are demonstrated using this phase shifter, and the results of the experiments that have been conducted using a prototype are presented. Additionally, this phase shifter exhibits frequency-gain characteristic. Therefore, we calculated the transmission loss of the silencer based on the assumption that this frequency-gain characteristic was canceled.

## 2. THEORY

### 2.1 Broadband silencing using a modified interference-type silencer

If we suppose that the main tube of an interference-type silencer is  $L_M$  and that the path length of the delay tube is  $L_D$ , the phase changes  $\theta_M$  and  $\theta_D$ , associated with the respective frequencies of the main tube and delay tube, are expressed using the following equations.

$$\theta_M = \frac{2\pi f L_M}{c} \quad (1)$$

$$\theta_D = \frac{2\pi f L_D}{c} \quad (2)$$

where  $f$  denotes the frequency and  $c$  denotes the sound velocity of the gas within the tube.

The difference between the phase changes  $\theta_M$  and  $\theta_D$  of the main tube and delay tube, respectively, are expressed using the following equation. Silencing can be achieved using the sound waves that are transmitted through the main tube and the sound waves that are transmitted through the delay tube by merging their reverse phases.

$$|\theta_M - \theta_D| = \left| \frac{2\pi f (L_M - L_D)}{c} \right| = (2n - 1)\pi \quad (n = 1, 2, \dots) \quad (3)$$

Additionally, by organizing the noise reduction frequencies  $f_{\text{peak}}$  in the above equation, we can obtain the following equation:

$$f_{\text{peak}} = \left| \frac{(2n - 1)c}{2(L_M - L_D)} \right| \quad (4)$$

In the actual silencer, the length of the main tube  $L_M$  and the length of the delay tube  $L_D$  are fixed. Therefore, even if the sound velocity  $c$  is continuously changed, the silencing peak continually occurs, enabling the achievement of good silencer performance over a wide range.

## 2.2 Conditions for merging the reverse phases of the frequency

Let us consider the conditions for merging the reverse phases of the sound waves transmitted in the main tube and those transmitted in the delay tube without depending on the frequency.

An acoustic structure having sound velocity  $V'$  allocated to the delay tube is depicted in Fig. 1. The phase change  $\theta_D$  of each frequency in the delay tube can be expressed using the following equation:

$$\theta_D = \frac{2\pi f L_D}{V'} \quad (5)$$

Based on Equations 3 and 5, the sound velocity  $V'$  can be obtained as follows:

$$V' = \frac{2cfL_M}{(2n-1)c + 2fL_D} \quad (6)$$

By allocating the materials that allow the sound velocity  $V'$  within the delay tube to satisfy Equation 6, the sound waves transmitted in the main tube and the sound waves transmitted in the delay tube exhibit a reverse-phase relation independent of the frequency. Additionally, when  $n = 1$ , Equation 6 can be rewritten as Equation 7.

$$V' = \frac{2cfL_M}{c + 2fL_D} \quad (7)$$

The sound velocity  $V'$  required for merging the reverse phases of the two aforementioned sound waves can be determined according to  $L_M$  and  $L_D$ .

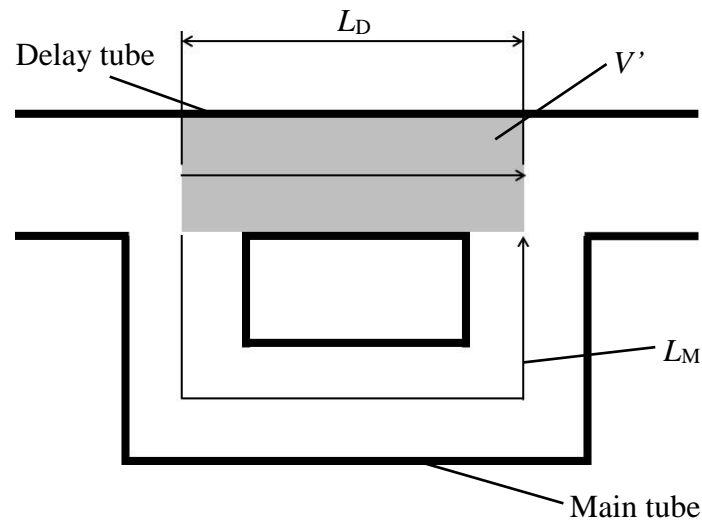

Fig. 1 - Interference-type silencer having an allocated acoustic structure.

### 2.3 Acoustic structures satisfying the conditions for reverse-phase merging

The acoustic structure that can satisfy the sound velocity  $V'$  conditions for the reverse-phase merging by allocating a delay tube can be considered to be a thin-plate acoustic structure with clearances. This acoustic structure utilizes the fact that the sound velocity in the clearances changes based on frequency due to the effect of the boundary layers. Further, an analytical method<sup>3</sup> for Stinson two-plane intersection was used to calculate the sound velocity in this acoustic structure. The propagation constant  $\gamma$  can be expressed using the following equation:

$$\gamma = j \frac{\omega}{c} \sqrt{\frac{\kappa - (\kappa - 1)B(s\sqrt{\sigma})}{B(s)}} \quad \left( B(x) = 1 - \frac{\sinh(x)}{x \cosh(x)} \quad , \quad s = \frac{b}{2} \sqrt{\frac{j\rho\omega}{\mu}} \right) \quad (8)$$

The real part of the propagation constant  $\gamma$  is the attenuation constant  $\alpha$ , whereas the imaginary part is the phase constant  $\beta$ . Therefore, the propagation constant  $\gamma$  can be expressed as follows:

$$\gamma = \alpha + j\beta \quad (9)$$

The sound velocity in the clearance between the two planes for each frequency can be calculated using the imaginary part  $\beta$  of the propagation constant  $\gamma$ , as denoted using the following equation.

$$V = \frac{\omega}{\beta} = \frac{2\pi f}{\beta} \quad (10)$$

From Equations 8 and 9, the variable in Equation 10 can be considered to be simply the thickness  $b$  of the clearance in Fig. 6. Therefore, the sound velocity  $V$  in the clearance between the two planes for each frequency  $f$  can be obtained by determining the thickness of the clearance.

### 2.4 Determining the dimensions by comparing the sound velocities

It is possible to obtain the sound velocity  $V'$  that satisfies the conditions for reverse-phase merging and the sound velocity  $V$  for the clearance between the two planes, which are observed to change based on the frequency. By comparing and matching these two velocities, clearance thickness  $b$  and tube lengths  $L_M$  and  $L_D$  can be obtained.

A comparison of the two sound velocities for 0.1 mm of the acoustic structure clearance thickness  $b$  is shown in Fig. 2. We can see that the difference between these two sound velocities becomes smallest when the gap thickness  $b$  is set to 0.1 mm, the tube length  $L_M$  of the main pipe is set to 290 mm, and the acoustic structure tube length  $L_D$  is set to 270 mm.

Using Equations 1 and 5, we calculated the amount of phase change as the tube length changed and the phase difference between the acoustic structure and the main tube. The

two values were subsequently compared. The results of this comparison are presented in Fig. 3. Generally, a value of 10 dB or more can be obtained as the transmission loss when the phase difference is within  $180^\circ \pm 15^\circ$ .

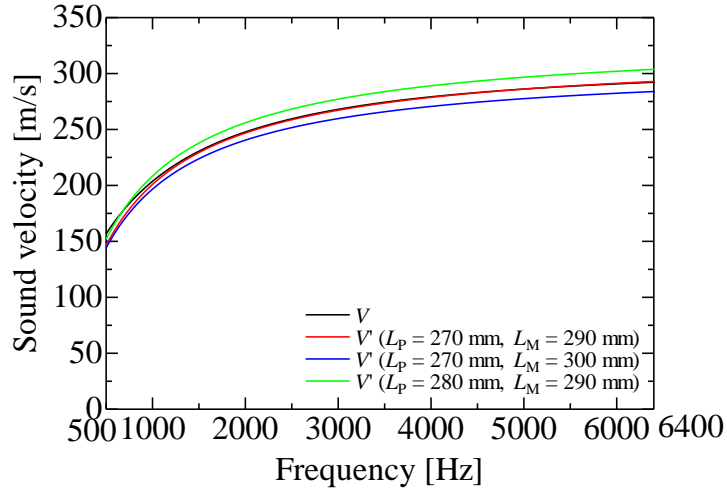

Fig. 2 – Comparison of sound velocity ( $b = 0.1$  mm).

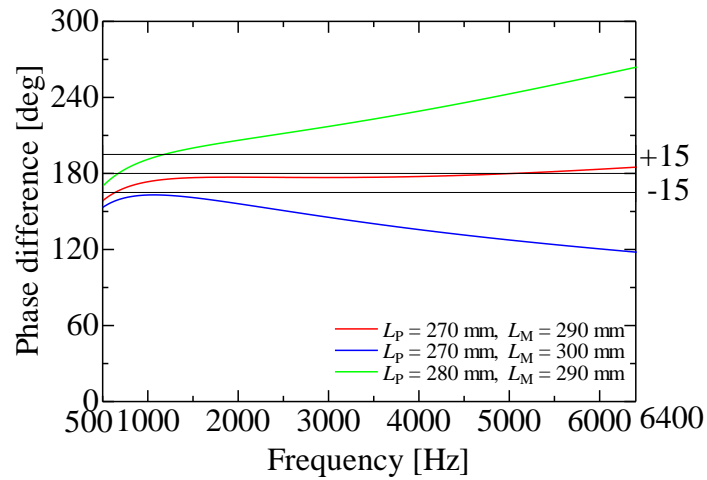

Fig. 3 – Comparison of phase difference ( $b = 0.1$  mm).

## 2.5 Silencing using the phase shifter

The sound waves passing through a phase shifter are attenuated and exhibit frequency-gain characteristic. Therefore, we consider a method that corrects the frequency-gain characteristic using a microphone, an equalizer, an amplifier, and a speaker, as depicted in Fig. 4.

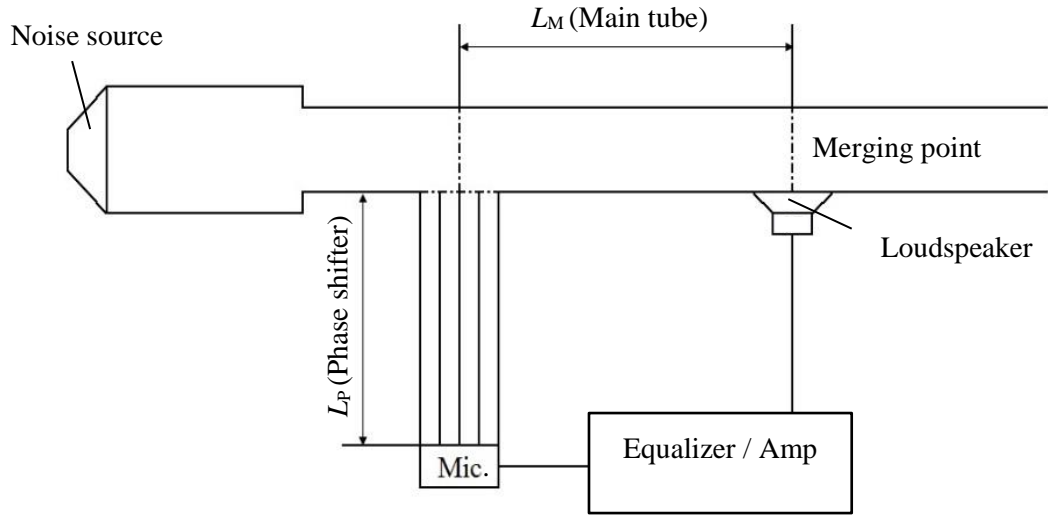

Fig. 4 – Schematic diagram of silencer.

## 2.6 Calculating the transmission loss

Here, we calculate the transmission loss by assuming the use of the device that has been described in the previous section. The sine wave  $y_I$  in the incidence portion of the phase shifter and main tube can be expressed using the following equation:

$$y_I = A \sin \omega t \quad (11)$$

At this time, the sine waves  $y_M$  and  $y_P$  for the main tube and phase shifter outputs, respectively, can be expressed using the following equation:

$$y_M = A \sin(\omega t + \theta_M) \quad (12)$$

$$y_P = B \sin(\omega t + \theta_P) \quad (13)$$

Additionally, the sine waves for which the frequency-gain characteristic have been corrected in the phase shifter-side sound waves can be expressed using the following equation:

$$y_P' = B \times n \sin(\omega t + \theta_P) = A \sin(\omega t + \theta_P) \quad (14)$$

The sine wave  $y_C$  of the associated waves can be expressed as follows while merging the sound waves based on the principle of superposition.

$$y_C = y_M + y_P' = C \sin(\omega t + \theta') \quad (15)$$

Transmission loss can further be calculated based on the amplitude  $C$  of the composite wave and original sound wave amplitude  $A$ , using the following equation.

$$TL = 10 \log_{10} \left( \frac{A}{C} \right)^2 \quad (16)$$

### 3. SAMPLES USED IN THE MEASUREMENT AND THE MEASUREMENT DEVICE

#### 3.1 Samples used in the measurement

The phase shifter used in the measurement is shown in Fig. 5, the dimensions of the phase shifter is depicted in Fig. 6, and the specifications are presented in Table. 1.

The phase shifter manufactured had the alternate superposition of a jig (thickness 0.1 mm) and thin plate (width 24.6mm, thickness 0.1 mm), which creates a clearance within a rectangular tube (outer size 25.6 mm×25.6 mm, internal size 24.6 mm×24.6 mm), the phase shifter was created by removing the jig after fixing the thin plate. In Fig. 5, we placed a paper with the letter “A” written on it behind the created phase shifter to indicate that there is a clearance.

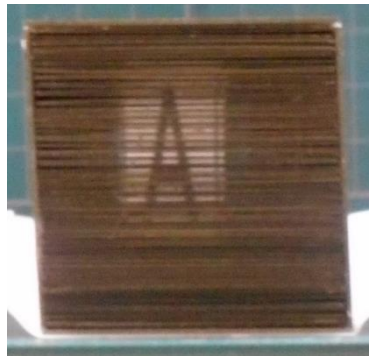

Fig. 5 – Manufactured phase shifter.

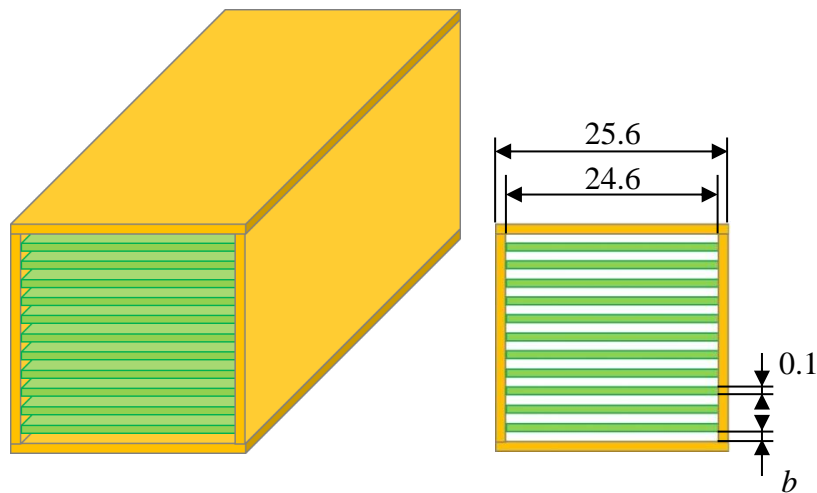

Fig. 6 – Phase shifter dimensions

Table. 1– Phase shifter specifications

|                              |       |
|------------------------------|-------|
| Clearance thickness $b$ [mm] | 0.1   |
| Tube length $L_P$ [mm]       | 270   |
| Number of thin plates        | 123   |
| Number of clearances         | 124   |
| Aperture ratio               | 0.536 |

### 3.2 A device for measuring the amount of phase change

While quantifying the amount of phase change, a *Brüel & Kjær* 4206T-type 4 microphone impedance tube and an FFT analyzer were used. A block diagram of the measurement device is depicted in Fig. 7. A reference signal was generated using the signal source, and the sound waves of the incident side and transmission side of the measured sample were detected by the microphone and analyzed using the FFT analyzer; further, the amount of phase change was quantified.

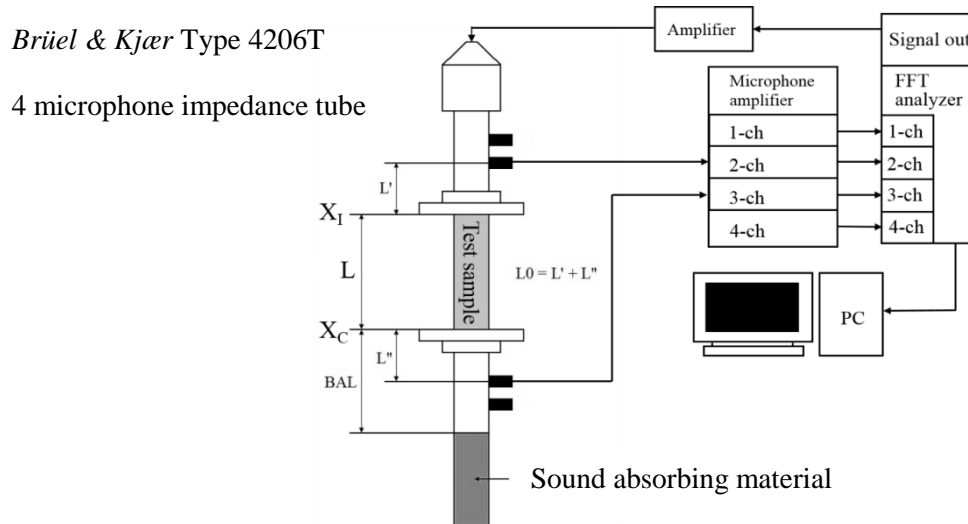

Fig. 7 – Block diagram of the measurement device.

## 4. COMPARISON BETWEEN THE THEORETICAL VALUES AND THE MEASUREMENT RESULTS

### 4.1 Amount of phase change

Figure 8 depicts the phase change quantity  $\theta_F$  in the phase shifter. While comparing the theoretical value and the experimental value, the experimental value at frequencies of lower than 1,600 Hz exhibited a smaller phase change than that exhibited by the theoretical value. However, at frequencies between 4,500 Hz and 6,000 Hz, the experimental value was larger than the theoretical value.

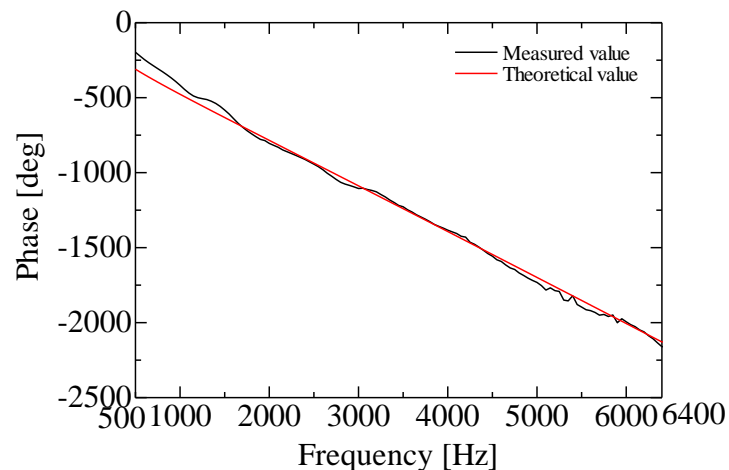

Fig. 8 – Amount of phase change of the phase shifter.



## 4.2 Transmission loss through the superposition of sound waves

The theoretical and experimental results of phase differences between the phase shifter and the empty tube are shown in Fig. 9. Using Equation 16 presented in section 2.6 and the results presented in Fig. 9, the calculated transmission loss discussed in section 2.6 is shown in Fig. 10.

Comparing Figs. 9 and 10, when the phase difference is within  $180^\circ \pm 15^\circ$ , estimated transmission loss of 10 dB can be obtained. Additionally, the transmission loss in Fig. 10 denoted that a portion had a negative value because when the phase difference is separated by  $\pm 60^\circ$  or more from  $180^\circ$ , as depicted in Fig. 9, the amplitude of the associated wave was amplified more than that before the association.

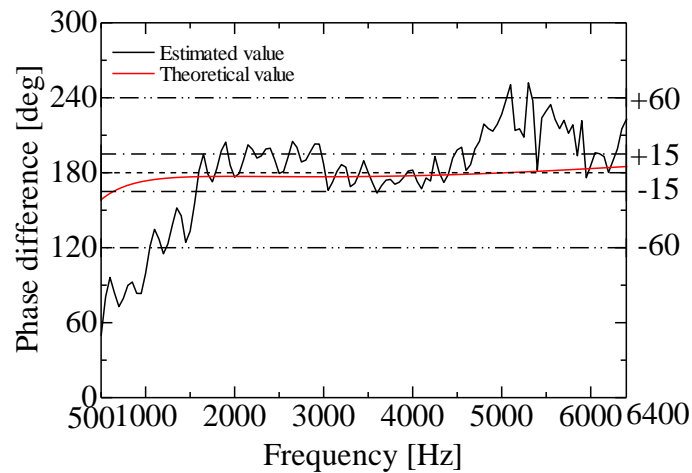

Fig. 9 – Phase differences between the phase shifter and empty tube.

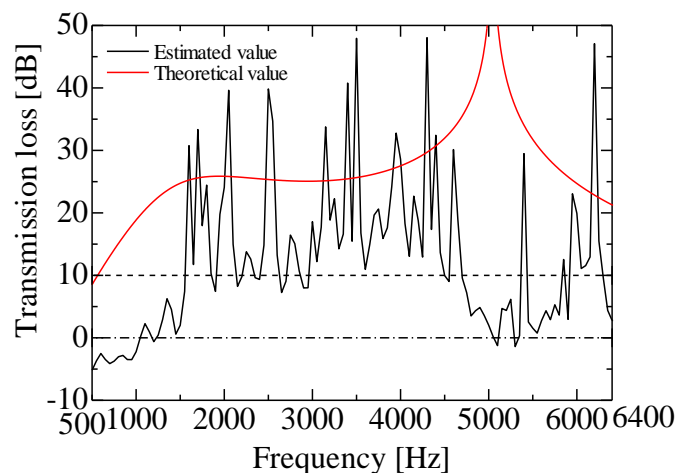

Fig. 10 – Transmission loss using the proposed silencing system.

## **5. CONCLUSIONS**

In this study, we propose a silencer that uses the frequency-sound velocity characteristic of a phase shifter with a clearance and superpositioned thin plates while demonstrating these principles. The frequency characteristic of the sound velocity within this acoustic structure were obtained both theoretically and experimentally, and the phase difference was obtained both experimentally and using calculations, which were further compared.

The assumed transmission loss of silencers using these results was estimated theoretically, and they were subsequently compared with experimentally estimated values. The experimental estimated value indicated that a transmission loss of 10 dB or more could be observed at frequencies of 1,600–4,500 Hz.

## **6. REFERENCES**

1. Landau, L. D., Lifshitz, E. M., Fluid Mechanics 2nd Edition, Butterworth-Heinemann, (1987).
2. Sakamoto, S., Higuchi, K., Saito, K., Koseki, S., Theoretical analysis for sound-absorbing materials using layered narrow clearances between two planes, *Journal of Advanced Mechanical Design, Systems, and Manufacturing*, Vol 8, No. 3, (2014), Paper No. 14-00302, 16 pages.
3. Stinson, M. R. and Champou, Y., Propagation of sound and the assignment of shape factors in model porous materials having simple pore geometries, *Journal of the Acoustical Society of America*. Vol 91, No. 2 (1992), pp. 685-695.