

Strategies to evaluate acoustic properties of timber hollow box floors

Homb, Anders¹
SINTEF Building & Infrastructure
Høgskoleringen 7b, 7465 Trondheim - Norway

Conta, Simone²
NTNU, Department of Civil and Environmental Engineering
Høgskoleringen 7a, 7491 Trondheim - Norway

ABSTRACT

The Norwegian project Woodsol aims at developing long span lightweight floors for timber buildings with increased spatial flexibility. One key element of the Woodsol system is the moment resisting frame consisting of pre-fabricated floor elements connected to continuous glulam columns. Each corner of the floor element is connected to the columns through steel connectors. The solution for floor elements is currently based on a hollow box with a resilient top floor. The construction systems shall fulfil the acoustic requirements for both commercial buildings, public buildings and apartments. The vibro-acoustic behavior and sound insulation properties shall be verified experimentally but standard building acoustic laboratory do not offer the required opening size of 8 to 10 m neither facilitate relevant flanking transmission setups.

This paper presents the strategy we adopted to accomplish the task. To both assess sound transmission and estimate the flanking transmission, we planned and performed experimental investigations based on vibration measurements on a mockup. Methods within this strategy cover Experimental Modal Analyses, Integral Transform Method and Junction Transmission Measurements. The purpose and principles of the methods will be presented together with some preliminary results.

Keywords: Vibro-acoustic measurements, Experimental setup, Wooden floor element
I-INCE Classification of Subject Number: 33, 72

1. INTRODUCTION

This paper describes the strategy we are following for investigating the vibro-acoustic behaviour of the Woodsol timber building concept. The Woodsol project aims at developing urban buildings up to eight or ten stories featuring large architectural flexibility [1]. The design is based on moment resisting frame consisting of pre-fabricated floor elements connected to continuous glulam columns. The solution of the floor element is based on a hollow, wooden box with a resilient top floor.

¹ anders.homb@sintef.no

² simone conta@ntnu.no

A first prototype of the floor showed that it is possible to achieve 8 to 10 m span with the hollow box concept, still fulfilling the comfort criteria on vibration behaviour [2]. No acoustic laboratory facilitates that level of span with, neither offers necessary options for estimating the flanking transmission properties. The concept is also in an early stage of development, and a real building with this system have not been build so far. To develop the concept and verify acoustic properties of the system, it was therefore necessary to establish a vibroacoustic strategy. A mockup have been built at Charlottenlund Videregående Skole (CVGS) for this purpose. A picture of the first setup is shown in figure 1. In the first part of the paper, the building concept and test object will be presented together with different experimental setup. Further on, the strategy itself will be presented. Finally, some example results will be given together with a discussion of further work.



Figure 1. Picture of the first setup of the Woodsol concept

2. TEST OBJECTS

2.1 Woodsol floor element

As mentioned, the WOODSOL floor element is of type hollow box. The current cross section is shown in figure 2. The top and bottom plates are KERTO-Q plates with thickness, respectively 43 mm and 61 mm. The outermost stringers are glulam GL30c, while the inner ones are glulam GL28c [3]. The cavity can be filled with gravel as needed according to the acoustic requirements. The cross section as shown is designed for a span length of approximately 9 m to 10 m.

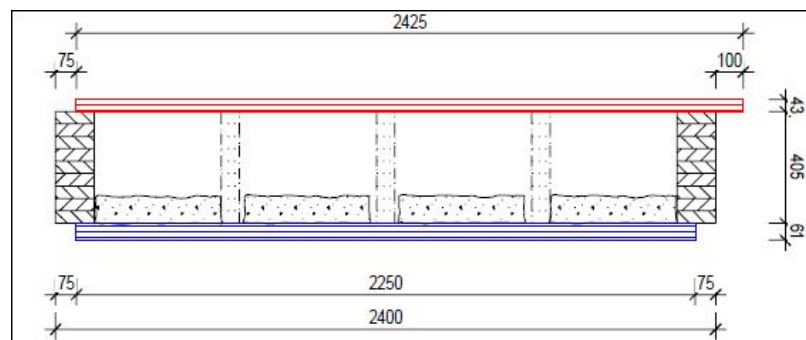

Figure 2. Cross-section of the Woodsol floor element [3]

We build prototype elements with the lengths 9 m, 4.7 m and 3.7 m. All of them have the same cross-section to ease the comparison of the results. The filling with gravel varies. The weight of the 9 m floor element without gravel is 2.4 ton. The weight of the 4.7 m floor element is 1.2 ton without gravel and approximately 2.4 ton with 100 kg/m² gravel in the cavity.

2.2 Woodsol connector

One of the targets of the Woodsol system is to realize a moment resisting frame with minimum use of additional bracing. The key element of the system is beside stiff floor elements, the connection between floor elements and columns. The principle of the Woodsol connector is based on a metal bracket installed to the floor element and to the columns using long threaded metal rods. These details are presented in [4]. In figure 3 a drawing and picture of the current prototype version is shown. This was used to mount the floor elements to the columns.

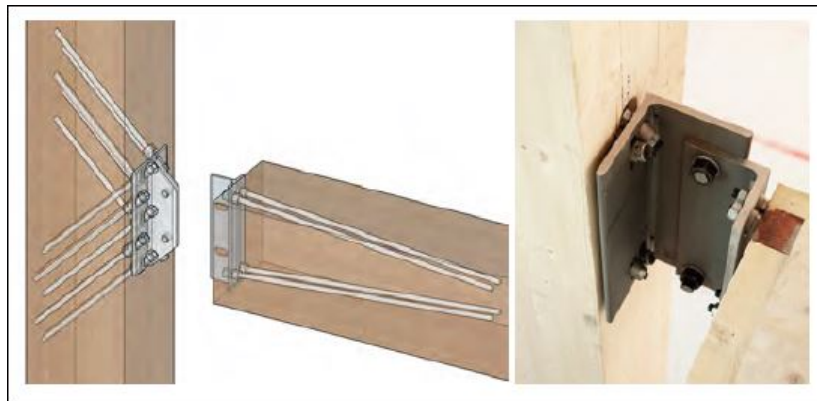

Figure 3. Drawing of the prototype connector and threaded rods, from [5]. Picture of the current prototype connector, photo from SINTEF.

2.3 Prototype configuration one

Table 1 show the scheduled measurement program for configuration number one with two identical floor elements, L1 and L2 mounted to six columns using one connector at each corner as shown in figure 4. All columns of 0.40 m x 0.45 m glulam elements were 5 m high. Their dimension is chosen according to the Woodsol project requirements and takes into account static requirement for a building up to eight stories. The floor is mounted with the bottom flange 2 m above the ground. The measurements are still ongoing while we are writing this paper.

Description/Setup	Scope	Excitation	Response
EMA, L1 Element on air bellows	Basic dynamic properties	Impact hammer	Acceleration at reference positions
EMA, L1 Element on columns	Effect of the mounting on the basic dynamic properties	Impact hammer	Acceleration at reference positions
ITM, L1 Element on columns	Estimate direct impact sound transmission	Tapping machine	Vibration velocity on lower surface
Structural reverberation time, L1 Element on columns	Collect data to characterize mock up	Impact	Acceleration at several positions
JTM, L1 & L2 Element on Columns	Estimate horizontal flanking sound transmission	Tapping machine on top, shaker on lower surface	Vibration velocity difference at selected surfaces

Table 1. Measurement program on floor elements for configuration one

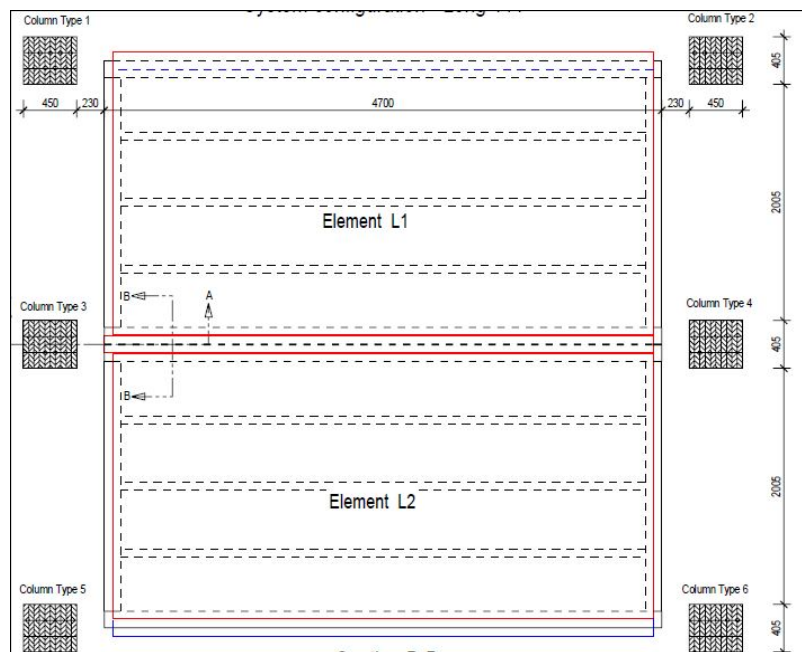

Figure 4. Configuration one with two identical floor elements

3. VIBROACOUSTIC STRATEGIES

To assess both sound transmission and estimate the flanking transmission, vibration transmission measurements at low and medium frequencies was planned. The strategy that we are following to develop suitable acoustical solution within the project includes the following three main steps:

- 1) assess basic vibroacoustic properties and collect data for model validation using the experimental modal analysis
- 2) study the sound radiation and impact sound insulation using the integral transform method
- 3) perform junction transmission measurements to study flanking transmission in the system.

Purposes and principles of the adopted measurement methods will be given in the following.

3.1 Experimental Modal Analysis (EMA)

The experimental Modal Analysis is used for assessing basic vibroacoustic properties and collection of data for model validation. The experimental activities were designed for validation of the numerical models, identify critical features of the Woodsol floor element and generally assess the vibration properties of the floor element, of the connectors and their interactions, see [6].

The measurements were performed using the roving hammer technique with several accelerometers as a reference, see figure 5. On the 4.7 m floor, a grid with 9 x 5 points (size 0.55 m x 0.56 m) and 7 reference accelerometers were used. The impacts were first recorded as time signals using a multichannel acquisition system and then post processed using the Abravibe toolbox [7] in Matlab. The settings of the measurement instruments and in the post processing were verified using the tools available in the abravibe toolbox. The AutoMAC criterion was used to assess how well the identified modes are decoupled and so check the quality of the mode identification [8].

To realize two types of boundary conditions, different experimental setups were used:

- free-free boundary condition, achieved by installing the floor element on top of air bellows. The resonance frequencies of the floor on the bellows were 3 Hz to 6 Hz.
- "on columns". To realize this setup, the current connector and threaded rod solution was used, see figure 1 and figure 3. The 9 m element will not be mounted on columns due to space limitations.



Figure 5. Illustrative picture of setup with the roving hammer technique

3.2 Integral Transform Method (ITM)

Starting from vibration velocity measurements, it is possible by the Integral Transform Method to calculate the radiated sound power in the wave number domain, and from that calculate the impact noise level in the receiving room. The reason for use of this method is the lack of wall elements in the mockup for traditional sound insulation measurements and the interest in the low frequency range. The Integral Transform Method (ITM) is gaining popularity and appeared to be a suitable tool. Although a number of references are available on the ITM, for instance [9] and [10], its application is not straightforward and requires an accurate planning of the measurements and a comprehensive analysis of the acquired measurement data. The procedure used for the

Woodsol project is described in [11]. Further references to theory and procedures is also given in this paper. The conditions on the grid size imply a high number of measurements points. To reduce the measurement time we can use the geometrical symmetry of the test object. The frequency range of interest for this work is 20 to 200 Hz. Due to the lack of experience with the method and possible uncertainties, the raster size was set to 24 cm in x direction and 30 cm in y direction. This should allow to obtain reliable measurements data up to at least 400 Hz. The accelerometers were mounted using magnets and special wooden screws to ensure rapidity of the measurements and proper connection of the sensor with the structure. A drawing of the raster with measurement positions is shown in figure 6.

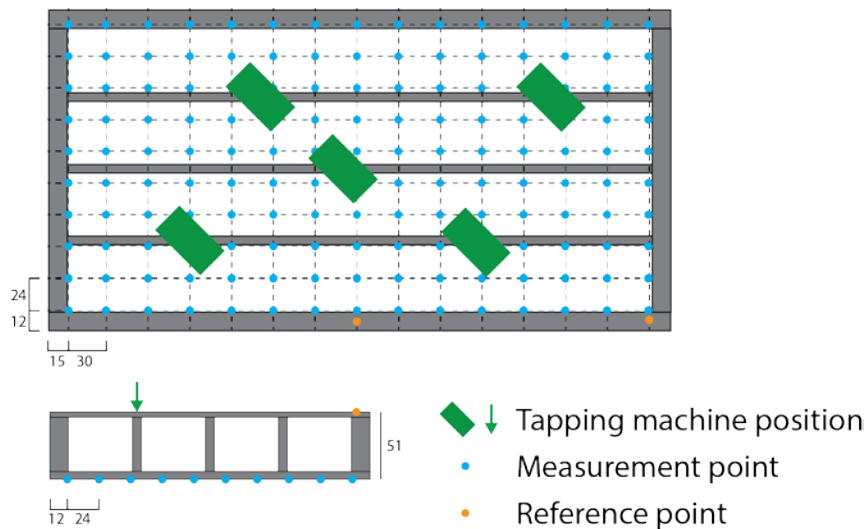

Figure 6. A drawing of the of the measurement positions for element L1

3.3 Junction Transmission Measurements (JTM)

Junction transmission measurements will be based on procedures given in ISO 10848, see [12]. The standard specifies measurement methods to be performed in a laboratory test facility in order to characterize the flanking transmission of one or several building components. The performance of the building components is expressed either as an overall quantity for the combination of elements and junctions or as the vibration reduction index, K_{ij} of a junction. The Woodsol mockup construction don't fit into the laboratory definition of a setup. But on the other hand, the boundary conditions of the structural elements are well described at the mockup, unlike ordinary field objects. Compared to the standard, the measurement procedure for the setup at CVGS will therefore be expanded. The number of measurement positions will be increased compared with the requirement in the standard. Both the upper surface and the lower surface of the floor element will be a part of the measurement program. The tapping machine will be used for excitation of the upper floor surface and a shaker will be used for excitation of the columns and lower floor surface.

Framed buildings are a class of building that can cause particular sound transmission problems. They are usually built with slender structures and large floor spans which enables sound and vibration to propagate easily through the structure. In this work sound transmission between columns and floors, and vice versa, will be studied to establish mechanisms of transmission through such gluelam building concepts. The connectors between floor element and columns in each corner is very stiff, and junction transmission properties are of crucial interest. But the floor elements may also be coupled together,

with more or less stiff compounds. The complete experimental program will therefore cover different element combinations and connections. Figure 7 show the principal setup of the main elements for the JTM measurements. A part of these measurements will also be to determine the structural reverberation time of the different elements [13].

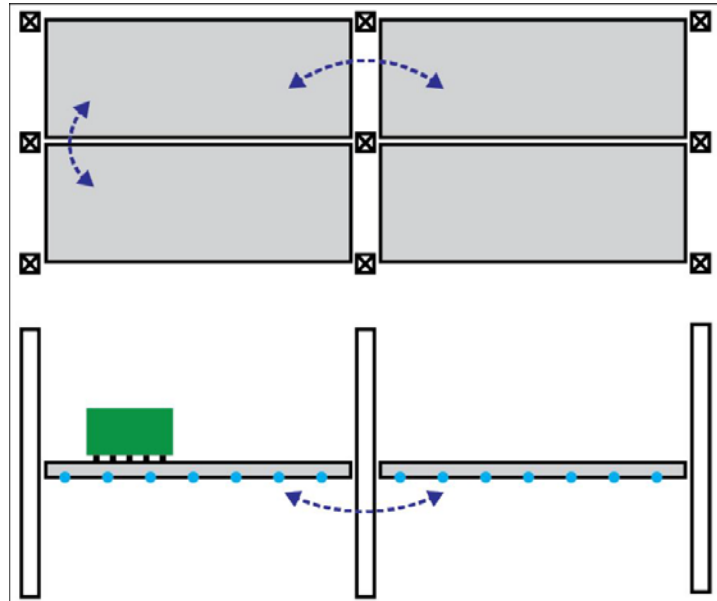

Figure 7. Concept of the experimental setup for junction transmission measurements

4. EXAMPLE RESULTS

4.1 Experimental Modal Analysis (EMA)

Results from EMA measurements on element L1 is presented below. Figure 8 show the amplitude of the measured transfer function acceleration/force for selected points on the 4.7 m floor installed on columns with the additional mass installed. In figure 9, examples of the identified mode shapes for the L1 element are presented.

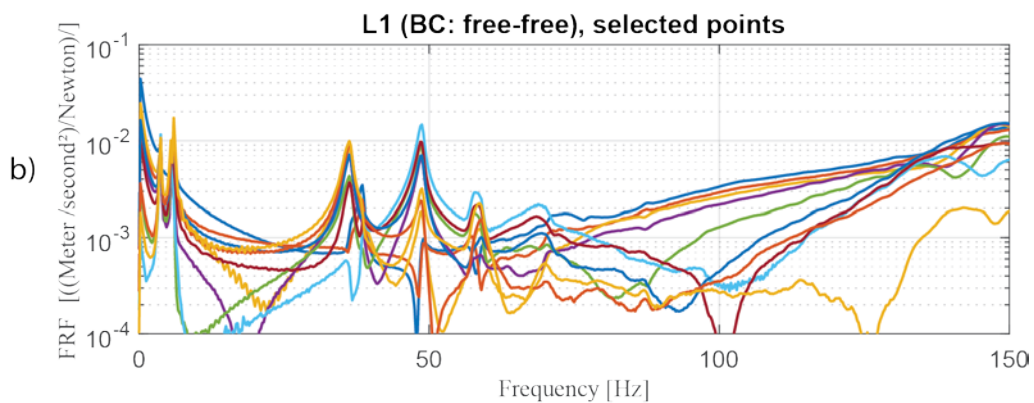

Figure 8. Transfer function for a selected point on element L1

Analysis and comments on the EMA measurements of the different element configurations will be presented in [6] and in a planned journal article.

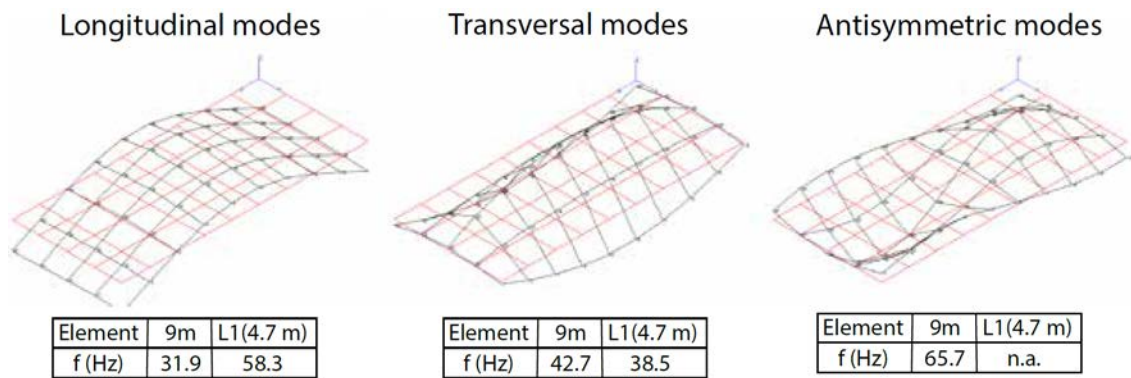

Figure 9. Selected mode shapes for the 4.7 m and 9 m element mounted on air bellows, from [6].

4.2 Integral Transform Method (ITM)

In figure 10 we show the vibration velocity distribution for the frequency steps 32 Hz (first bending mode), 42 Hz (first transversal mode combined with a torsional mode) and 66 Hz (higher order mode) measured on the 9 m element installed on air bellows. In the figure, the excitation positions are marked with white circles while the current active excitation position is highlighted in red. The results match fairly well the frequencies and mode shapes obtained from the experimental modal analysis performed on the same experimental setup.

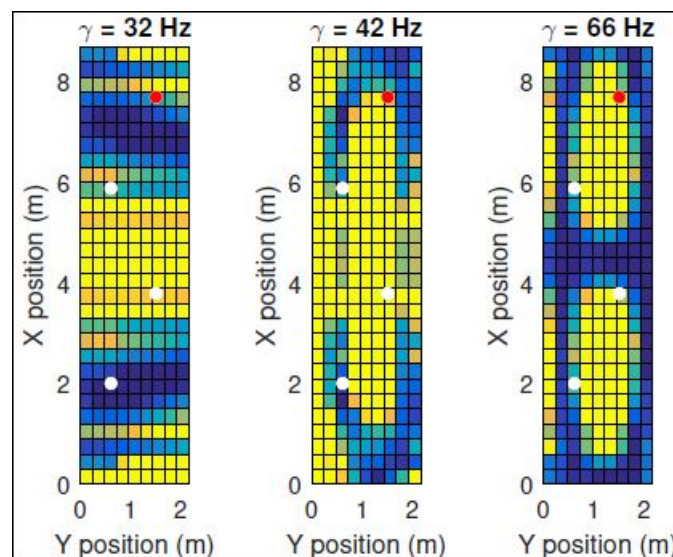

Figure 10. Measured vibration velocity distribution, from [11].

The normalized impact noise level calculated from the energetic average of the measured sound power is shown in figure 11 in 1/3-octave bands up to 400 Hz. The local maxima around the eigenfrequency of the first mode (32 Hz) confirm the expectation that the long span might lead to characteristic features in the spectrum at low frequencies. For reference we show in the same diagram the normalized impact noise level measured in a lab for a CLT floor element with similar mass per unit area ($m' = 85 \text{ kg/m}^2$), from [14]. The latter result are from standardized laboratory measurements and therefore data is only available above 50 Hz. The results show that the preliminary results for the Woodsol element above 100 Hz is very similar to that for a CLT panel of comparable mass per unit area. The strong differences below 100 Hz could be due to the boundary conditions, the size of the element and the stiffness properties of the design. Analysis of other lengths of

the Woodsol elements will be carried out throughout the project and results will also be verified with complete measurements in an acoustic laboratory.

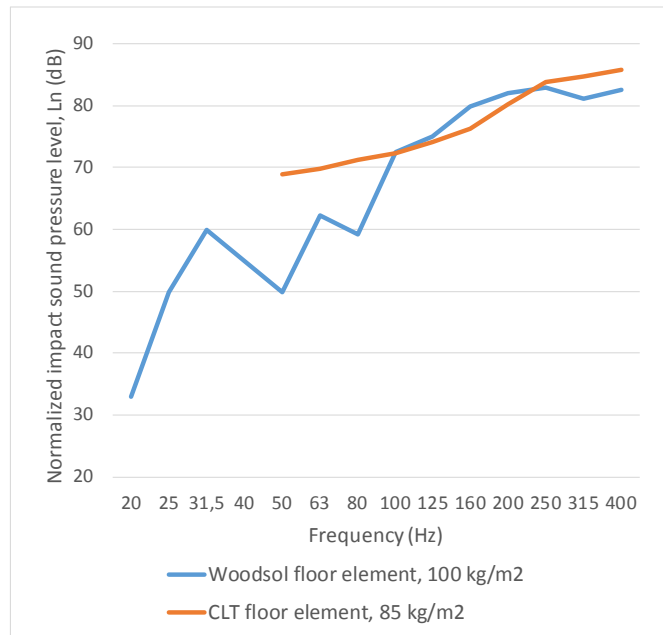

Figure 11. Impact noise levels calculated from vibration velocity measurements on the Woodsol element compared with laboratory measurement of a CLT floor element [14].

4.3 Junction Transmission Measurements (JTM)

Some preliminary results from JTM measurements on element L1+L2 is presented below. Figure 12 show the velocity level difference calculated from the average vibration velocity on the top flange of L1 and the average vibration velocity on the bottom flange of L2. The excitation was applied with a shaker connected at four different positions on the bottom flange of L1. Pink noise and repeated measurements on several frequency bands were used to improve the signal to noise ratio.

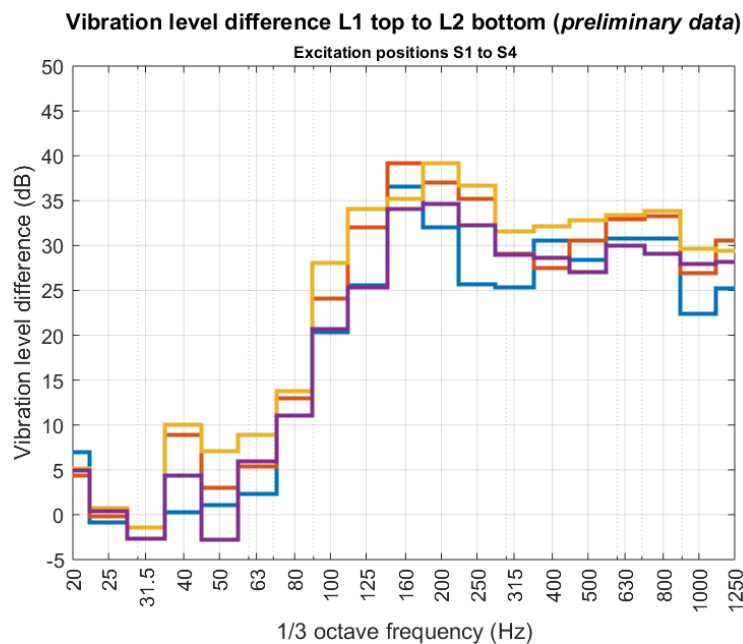

Figure 12. Vibration velocity difference from selected measurement positions on the first Woodsol configuration.

A number of JTM measurements will be carried out, involving both different excitation principles, source positions (including excitation of the columns) and receiving positions on the floor element. Analysis of results from these measurements will also be submitted to a journal paper later on. Data will make it possible to analyse the vibration transmission and further on calculate the flanking transmission contribution according to EN-ISO 12354.

5. FURTHER WORK

When this paper is written, EMA, ITM and JTM measurements on configuration one is about to end. Except ITF, the same measurement program will be carried out for configuration two, three and four. In configuration two, the long elements will be (more or less stiff) connected in the main direction of the floor. In configuration three, two elements will be connected to the columns at the short section of the elements, while the same elements will be (more or less stiff) connected together through an intermediate element in configuration four. The total measurement program will then cover important and relevant combination of floor elements without interrupting the overall principle with the moment resisting frame through steel connectors at each column. The measurement results will be used for extensive analysis in terms of both sound transmission and input for flanking transmission calculations. Outcome from these measurements and analysis will be presented in journal papers and conference papers.

6. ACKNOWLEDGEMENTS

This study has been carried out within the Woodsol project, a project funded by the Norwegian Research Council. The project include research at NTNU and SINTEF Building & Infrastructure and the PhD grant for the second author of this paper which is gratefully acknowledged. PhD-colleagues at NTNU, Sveinung Nesheim and Aivars Vilguts were also involved in the design and construction of the WOODSOL prototype and Leif Joar Lassen and students from Charlottenlund Videregående skole in Trondheim (NO) greatly supported us during the construction of the prototype.

7. REFERENCES

1. Woodsol project summary, <http://www.woodsol.no>
2. Bjorge, V., Kristoffersen, T. *Konseptstudie av trebaserte komposittdykker med mulighet for innspenning til limtresoyler*. Master thesis, NTNU, Trondheim 2017.
3. Halstedt, H. *Woodsol prototype element production drawings*. SINTEF Building & Infrastructure, Trondheim, Norway (2018).
4. Malo, K.A., Stamatopoulos, H. *Connections with threaded rods in moment resisting frames*. Proceedings of the World Conference on Timber Engineering (WCTE 2016), pp. 158-176, Wien, Austria, 2016. ISBN 978-3-903024-35-9.
5. Vilguts, A., Malo, K. A., Stamatopoulos, H. *Moment resisting frames and connections using threaded rods in beam-to-column timber joints*. Proceedings of the World Conference on Timber Engineering (WCTE 2018), Aug. 20-23, 2018, Seoul. ISBN 979-11-6019-253-3.
6. Conta, S., Homb, A. *Experimental modal analysis on Woodsol hollow box floor elements*. Submitted for 26th International Congress on Sound and Vibration, ICSV26, 7-11 July 2019, Montreal, Canada.

7. Brandt, A. *Notes on using the ABRVIBE Toolbox for Experimental Modal Analysis*, <http://www.abravibe.com>
8. Brandt, A. *Noise and Vibration Analysis, Signal Analysis and Experimental Procedures*. JohnWiley and Sons, (2011).
9. Kohrmann, M., *Numerical Methods for the Vibro-Acoustic Assessment of Timber Floor Constructions*. In Ingenieur fakultät Bau Geo Umwelt (BGU) 2017, Technische Universität München.
10. Schoenwald, S., Vallely, S. and Troebs, H.M. *Advanced methods to determine sound power radiated from planar structures*. The Journal of the Acoustical Society of America, 2017. 141(5): p. 3713-3713.
11. Conta, S., Homb, A. *Challenges and limitations using the Integral Transform Method to obtain the impact noise level of timber floors*. Proceedings of Euronoise 2018, M. Taroudakis (Ed.), Crete, May 27-31, 2018 (pp.: 667-674), ISSN: 2226-5147.
12. ISO 10848. *Acoustics. Laboratory measurements of the flanking transmission of airborne and impact sound between adjoining rooms*. Part 1: Frame document. ISO 2016.
13. Conta S., Ulrich S., Homb A., *Structural reverberation time measurements according to ISO 10848 on WOODSOL prototype*. ICA2019, Aachen (abstract submitted)
14. Homb, A., Guigou-Carter, C. and Rabold. A. *Impact sound insulation of cross-laminated timber/massive wood floor constructions: Collection of laboratory measurements and result evaluation*. Building Acoustics, 2017. 24(1): p. 35-52.