

Analysis of a vehicle-mounted self-stabilized p-u probe as a continuous spatial acoustic impedance measuring system for studying road surfaces

Luca Fredianelli¹, Francesco Bianco², Matteo Bolognese¹, Paolo Gagliardi¹, Fabio Lo Castro³, Francesco Fidecaro¹, Gaetano Licitra⁴

¹ **University of Pisa, Physics Department
Largo Bruno Pontecorvo, 3 - 56127 Pisa, Italy**

² **IPOOL srl
Ripa Castel Traetti, 1 - 51100 Pistoia, Italy**

³ **INSEAN-CNR
Via di Vallerano, 139 - 00128 Rome, Italy**

⁴ **ARPAT
Via Giovanni Marradi, 114 - 57125 Livorno, Italy**

ABSTRACT

The knowledge of the acoustic impedance of a material allows to calculate its acoustic absorption. Furthermore, it can also be linked to some of the material's structural and physical proprieties by means of adequate models. However, while measuring the acoustic impedance of pavement samples in laboratory conditions can be usually achieved by using high accuracy equipment, such as the impedance tube, a complete in-situ evaluation of the paving results less accurate than the laboratory one and is extremely time consuming, enough to make a full scale implementation of in-situ evaluations practically impossible. Such a system would be necessary for evaluating the homogeneity and the correct laying of a road surface, which is proven to be directly linked to its acoustic emission properties.

In the presented work, a measurement instrument fixable to a moving laboratory, such as a vehicle, is studied to overcome the issues that afflict in-situ measurements and thus allowing a continuous spatial characterization of a given pavement and a direct evaluation of the surface's quality. A calibration method will be shown, together with the evaluation of the performances of the system as an acoustic measure instrument.

Keywords: Road surfaces, Acoustic impedance, p-u probe

I-INCE Classification of Subject Number: 72

1. INTRODUCTION

Transportation noise pollution represents a widespread issue for modern society, especially in urban areas. Indeed, after 15 years from the 2002 European Environmental Noise Directive (END) emission, a revision [1] reported that noise pollution still represents a serious health problem in Europe, with road traffic representing the most

common noise source. About 100 million people in the 33 EU member states are exposed to harmful road traffic noise levels exceeding 55 dB(A) of L_{den} , and 32 million are exposed to noise levels higher than 65 dB(A) of L_{den} . An exposure to these levels could lead to a series of issues, such as sleep disorders with awakenings [2], learning impairments [3], cardiovascular, hypertension and ischemic heart disease [4] and annoyance [5]. One of the solutions adopted by the END is the institution of mandatory action plans for big infrastructures or urban agglomerations [6].

The study of noise generation mechanisms is of paramount interest in order to optimize mitigation actions and studies [7, 8] shown that tyre-road noise is a remarkably complex phenomenon. It results from the combination of airborne and structure-borne phenomena, where the source is provided by the contact between tyre and pavement. Airborne noise is related to compression of the air trapped within the tread of the rolling tyre [9]. These mechanisms are known as air pumping, and cause noise at frequencies higher than 1 kHz. Other than air pumping, airborne mechanisms also include pipe and Helmholtz resonances, due to the coupling of a vibrating mass of air within the tread, which acts as a cavity. Moreover, the effect of ageing can be particularly dramatic on the acoustic performance of some porous surfaces. Road traffic and weathering causes the voids in the surface to become clogged with detritus reducing acoustic absorption, resulting in increased noise levels even more than 5 dB [10, 11].

Different methods are generally used to evaluate the acoustic properties of a pavement: from the CPX method [12], that also evaluated the emission properties, to the absorption measurement performed with the spot method based on an impedance tube (ISO 10534) [13] and the Adrienne method (ISO 13472-1) [14].

An experimental method derived from the Adrienne one was presented in 2014 [15], aiming to overcome other methods weakness. A new in-situ acoustical absorption coefficient measurement system is implemented on a mobile Laboratory, based on pressure-velocity probe (p-u probe), in development inside the NEREiDE LIFE project.

Measurements have been performed in order to calibrate the instrumentation and Finite Elements Methods (FEM) simulations are added in order to improve the analysis.

2. MOBILE LABORATORY ABSORPTION MEASUREMENT MODEL BASED ON P-U PROBE

Measuring the absorption coefficient of a road surface with a moving vehicle requires a contactless measurement method, such as the Adrienne [16] and its variation using a pressure velocity, p-u, probe instead of the microphone only [17, 18].

The model used in this work considers an acoustic monopole source located over the ground at height h_s and a receiver with height h_r from the ground as shown in Fig. 1. The receiver records both the acoustic pressure, p , and the particle velocity, u [19]. An innovative stabilization system is used to reduce the variation of the height of the source and the receiver in accordance to their sensitivities.

The acoustic impedance at the receiver is calculated with Equation 1 from the ratio of the complex pressure to complex velocity amplitudes.

$$Z_r(r, \omega) = \frac{p_r(r, \omega)}{u_r(r, \omega)} \quad (1)$$

The pressure and velocity values are calculated with Equations 2 considering a spherical wave:

$$p(r, t) = \frac{A}{r} e^{-kri} e^{i\omega t} \quad u(r, t) = \frac{A}{\rho cr} \left(1 - \frac{i}{kr}\right) e^{-kri} e^{i\omega t} \quad (2)$$

where A is the wave amplitude, ρ is the air density, c is the speed of sound, $\omega = 2\pi f$ is the angular frequency, $k = \frac{2\pi}{\lambda} = \frac{2\pi f}{c}$ is the acoustic wave number, λ is the wavelength.

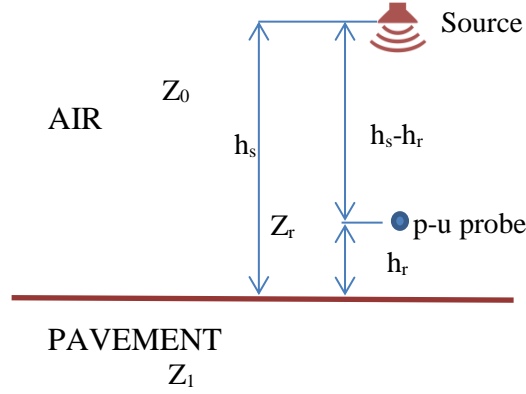

Figure 1: Geometrical set-up of the absorption coefficient measurement system

The value of the absorption coefficient, α , is defined as $\alpha = 1 - \Gamma$, where Γ is the reflection coefficient defined in Equation 3 as the ratio of the reflected power, P_r to incident power P_i .

$$\Gamma = \frac{P_r}{P_i} \cong \frac{|p_r|^2}{|p_i|^2} = |R|^2 \quad (3)$$

where R is the sound pressure reflection factor. The pressure at the microphone is the sum of the direct and reflected pressure wave. In the same way the velocity at the u probe is the sum of direct and reflect velocity wave, but considering the versus. The impedance is then reported in Equation 4.

$$Z_r(r, t) = \rho c \frac{\frac{1}{d_1} e^{-kd_1 i} + R \frac{1}{d_2} e^{-kd_2 i}}{\frac{1}{d_1} \left(1 - \frac{i}{kd_1}\right) e^{-kd_1 i} - R \frac{1}{d_2} \left(1 - \frac{i}{kd_2}\right) e^{-kd_2 i}} \quad (4)$$

From the previous equation R can be obtained Equations 5 and 6.

$$R(r, t) = - \frac{(h_s + h_r) \left(\frac{Z_r [k(h_r - h_s) + i]}{\rho c k (h_r - h_s)} - 1 \right)}{(h_r - h_s) \left(\frac{Z_r [k(h_s + h_r) - i]}{\rho c k (h_s + h_r)} + 1 \right)} e^{-2kh_r i} \quad (5)$$

$$|R|^2 = \left[\left(\frac{h_s + h_r}{h_s - h_r} \right) \left| \frac{\frac{Z_r [-k(h_r - h_s) - i]}{\rho c k (h_r - h_s)} + 1}{\frac{Z_r [k(h_r + h_s) - i]}{\rho c k (h_r + h_s)} + 1} \right| \right]^2 \quad (6)$$

In order to know which parameter majorly affect the value of α , the sensitivity of α respect to h_s or h_r can be calculated with Equations 7.

$$\frac{\partial \alpha}{\partial h_r} = \frac{\partial |R|^2}{\partial h_r} \quad \frac{\partial \alpha}{\partial h_s} = \frac{\partial |R|^2}{\partial h_s} \quad (7)$$

Considering that vehicle's height from the surface changes with vehicle acceleration and speed or for irregularities in the pavements, in the previous study [15] Matlab computation were performed in order to find the best height of the receiver from the road, i.e. the height with smallest error in the calculation of the

absorption coefficient. The results showed that the best height for the probe is at 0.16 m from the pavement, which is what has been used in the present work.

Adrienne and the new one methods' principal features are summarized in Table 1. The new method offers a wider frequency band width and less sensitivity to the receiver height variation in the absorption measurement, which makes it more appropriate for a running vehicle.

	Adrienne Method	Adopted Method Based On P-U Probe
In Situ Measurement	✓	✓
Contactless Measurement	✓	✓
Frequency Bandwidth	250Hz÷4kHz	315Hz÷10kHz
Exposed Area Diameter	≈ 1.4 m	≈ 1.4 m
Height Of The Sound Source	1.25 m	1.5 m
Height Of The Sound Microphone / P-U Probe	0.25 m	0.16 m
Absorption Coefficient Sensitivity To Receiver Height Variation ($F \geq 315$) [1/m]	2.4	2.1
Absorption Coefficient Sensitivity To Source Height Variation ($F \geq 315$) [1/m]	0.5	0.3

Table 1: Comparison of in-situ measurement methods.

2. VEHICLE MOUNTED P-U PROBE

As previously reported, in a running vehicle the frame to ground distance changes because of shocks or discontinuity of the pavement. This is also valid for the absorption measurement system, which is connected to the frame and hence it will suffer its same oscillations. This unwanted phenomenon can be reduced by uncoupling the measurement system from the frame through a system that maintain constant the distance from the measurement system and the pavement.

As shown in figure 2, a controller on the distance can be obtained with a PID controller applied to a damping, which acts on the error given by the difference of the target position and the present position the measurement system respect to the pavement. Furthermore, the PID controller takes into account the error, its integrate I, and its derivate D.

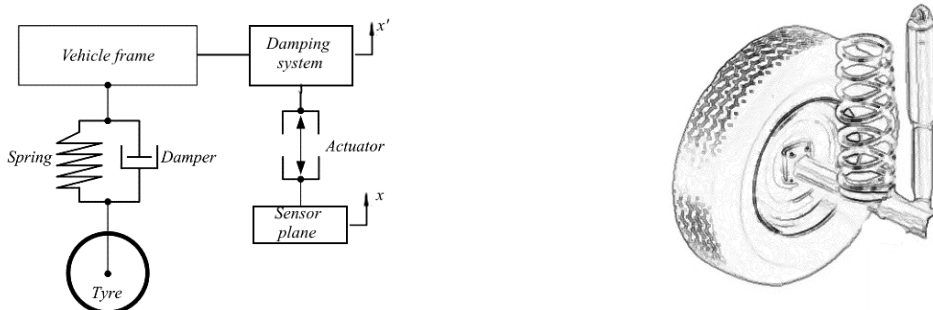

Figure 2 – Damping system model of the absorption measurement system

The p-u probe in Figure 3 has been conceived in order to simultaneously and directly detect the pressure and particles velocity in a given point and it consists of a miniaturized pre-amplified microphone measuring the pressure and a sensor that

evaluates the particles velocity that exploits the local heat transfer induced by the air flow between two thin wires [20].

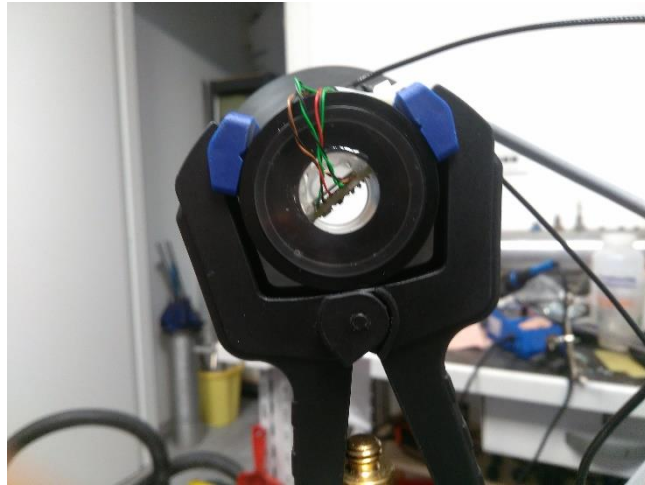

Figure 3 – p-u probe.

Before the p-u probe, particles velocity was detected using two matched microphones separated by Δr , and was calculated through the difference over the simultaneous pressure measurement. Two major issues generally occur for this kind of measurement: Δr should be enough to have a relevant pressure variation among the microphones and the microphone dimension itself can interfere with the sound field.

The thin wires method overcome these issues. In fact, the particle velocity is here evaluated from the value of the wire electric resistance, which varies with temperature and with the speed of the air flowing over the wire. The velocity, u , is then evaluated with Equation 8, where E is the voltage difference at the edges of the wire resistance, a , b and n are three constants evaluated during calibration.

$$u = \left(\frac{E^2 - a}{b} \right)^{1/n} \quad (8)$$

3. A FIRST CALIBRATION APPROACH OF THE P-U PROBE

The probe calibration process involves several possible phases, each based on a different methodology. Calibrating an instrument consists of measuring the same quantity with both the used and the reference instruments before comparing the results obtained. While the calibration of a microphone can be performed with a suitable calibrator (for example the pistonphones), no standard speed references to rely on exists for speed probes. For this reason, it is necessary to measure the acoustic impedance, which is given by the ratio between the velocity values of the particles and pressure measured at the same point.

The calibration measurement can be performed inside an anechoic chamber or, alternatively, inside a stationary wave tube (or impedance / Kundt tube). Alternatively, it is possible to perform a calibration by making a comparison with the Adrienne method for measuring the absorption coefficient of a material from its surface acoustic impedance, actually usable for the calibration process.

The Adrienne method is achieved in principle by sending an impulsive signal to a surface, measuring both the direct incident pulse and the reflected response of the

material. The source and the microphone recording the impulse are placed at a fixed distance between each other and between them and the measured surface as shown in Figure 4. The direct impulse is also measured in the hypothesis of absence of reflection: from the subtraction of the first signal, containing both the direct and reflected impulse, and the second, containing only the direct one, the signal reflected by the surface is then obtained. By taking into account the geometric dispersion is then possible to calculate the surface acoustic impedance.

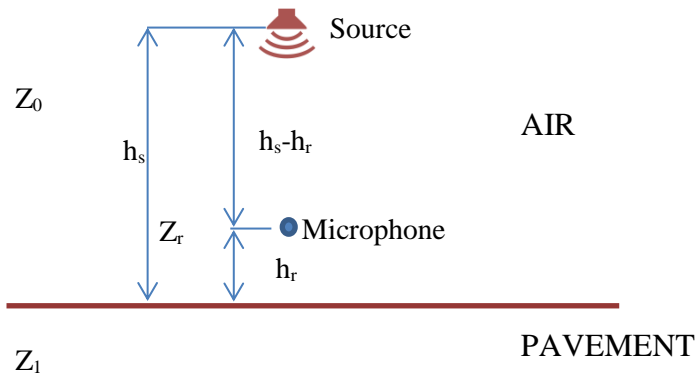

Figure 4 – Geometrical set-up of the Adrienne measurement system

By replacing the microphone with the P-U probe it is possible to calculate the value of the sound field impedance, from which the absorption coefficient is obtained. The calibration coefficient, a complex value function of the frequency, is calculated by the following expression:

$$C = \frac{Z_{probe}}{Z_{test\ set}}$$

Obtaining a good physical impulse signal is generally difficult, so an MLS signal of order 18 has been chosen to carry out the measurements. This signal can be approximated to a white noise, hence considered as such, while allowing to reconstruct the impulse response.

In order to exclude the effect of box heating, repeated impulse response measurements were performed and no differences were found when comparing the results.

With the set-up shown in Figure 4, a first set of measurements was made to measure the impulse response without an absorbent medium, then to measure the direct test signal. Subsequently, multiple absorption measurements were performed with Adrienne method and with the P-U probe for different thicknesses of melamminic foam rubber, obtained by stacking identical sheets of the material. In Figure 5 the absorption results; the sample size is the main cause of the oscillation that can be seen for the less absorbent measurements.

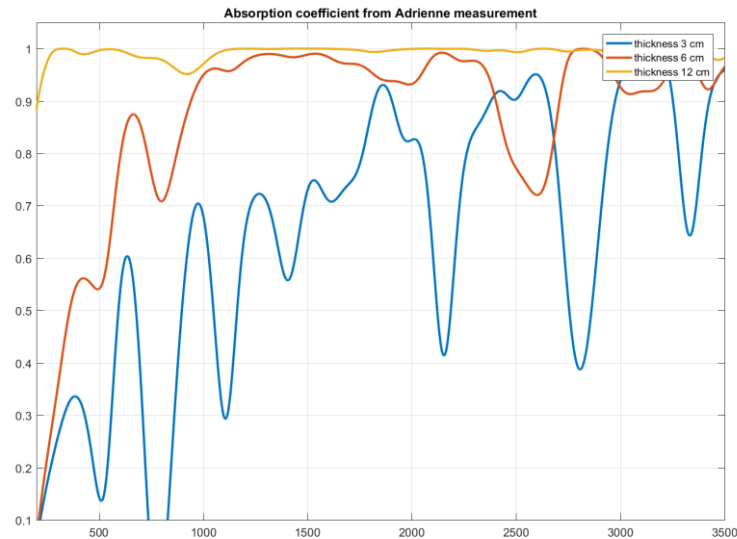

Figure 5 – Absorption coefficient from Adrienne measurement.

The probe calibration is then performed via two different approaches. The first one uses only the direct pulse measurement as a test set, comparing it with the theoretical evaluation of the spherical wave impedance $Z_{0_{sph}}$.

$$Z_{0_{sph}} = \rho_0 c_0 \frac{kr}{kr - i}$$

The second approach uses instead one of the measured stacks of material as a test set, in particular the thickest one achieved of approximately 12 cm, formed by 4 identical layers. In this case the acoustic impedance obtained by the probe is compared to the measurement by the Adrienne method.



Figure 6 – Measurements set-up.

According to [21], an acoustic velocity horn was mounted because it delivers a significant velocity amplification. All measurements were made keeping the horn axis orthogonal to the material and aligning its entrances with the established measuring point. The measurements made with the probe once processed reveal the presence of two impulses, the incident and the one reflected by the material and other small peaks due to uncontrollable spurious reflections.

Unfortunately, the results were not acceptable because of the incomplete understanding of the horn's behaviour. The theory used to treat the effect on the incident acoustic field was formalized for a plane wave, while in the present study a spherical wave is used, for which a full comprehension is not easy. Thus, the measurements have been repeated without the horn.

Removing the horn causes a reduction in the signal-to-noise ratio since the necessary amplification by the horn is missing. In spite of this, the analysis of the measurements has led to a more satisfactory result for both calibration approaches, as reported in Figure 7. The system is able to reproduce the absorption curve of the material, albeit with obvious errors.

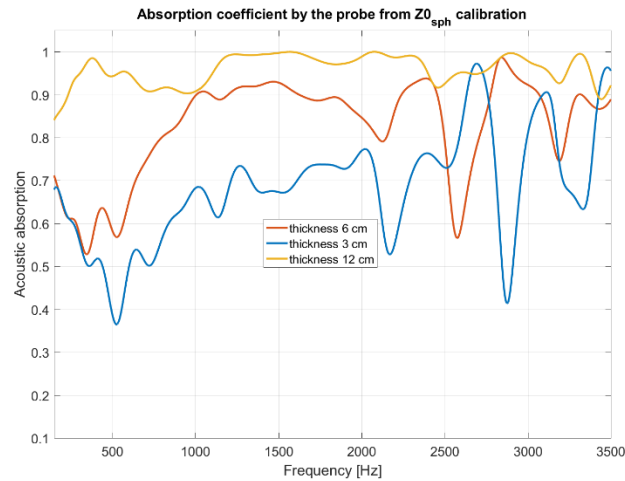

Figure 7a – Sound absorption of foam rubber – $Z0_{sph}$ calibration method

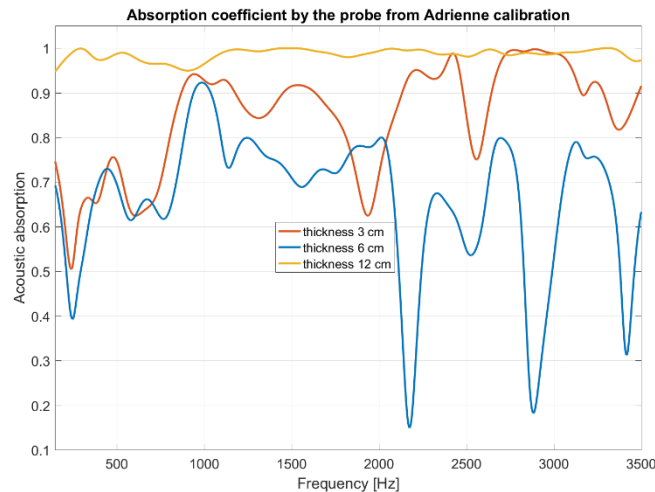

Figure 7b – Sound absorption of foam rubber – Adrienne calibration method

In order to better evaluate and comprehend the phenomena affecting the measurements carried out, Finite Element Method (FEM) simulations of the probe were performed. The evaluation of an outgoing spherical wave is carried out in order to assess a basic FEM setup, as shown in Figure 8a. Then another simulation is performed by placing a small cylinder around the point in which the pressure and velocity are calculated, as seen in Figure 8b: this roughly represents the actual

conditions of the p-u probe, whose sensors are installed in a small cylinder of approximately 3 cm of length and 1 cm of diameter.

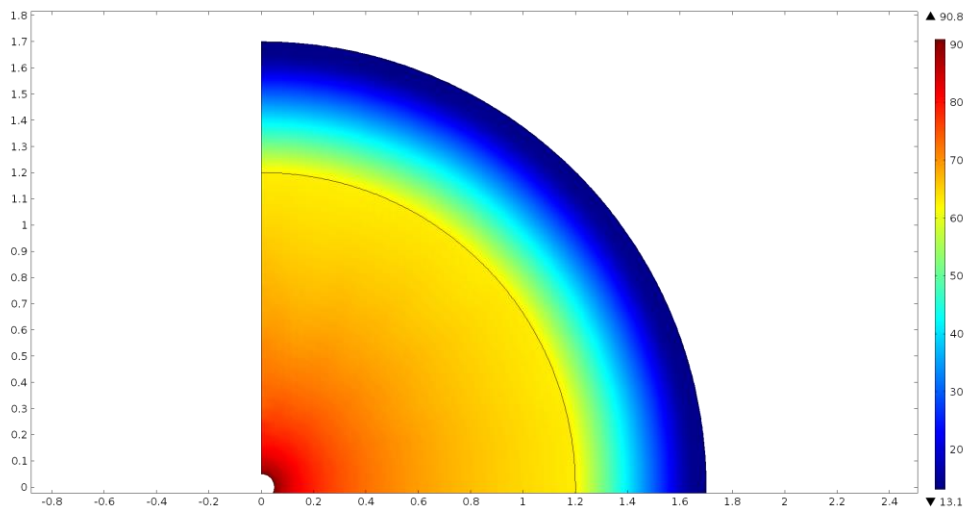

Figure 8a – FEM simulation of spherical free field. The sound pressure level is shown as obtained at 4500 Hz and a perfectly matched layer that absorbs all the outgoing energy is clearly visible in the outer layer of the picture.

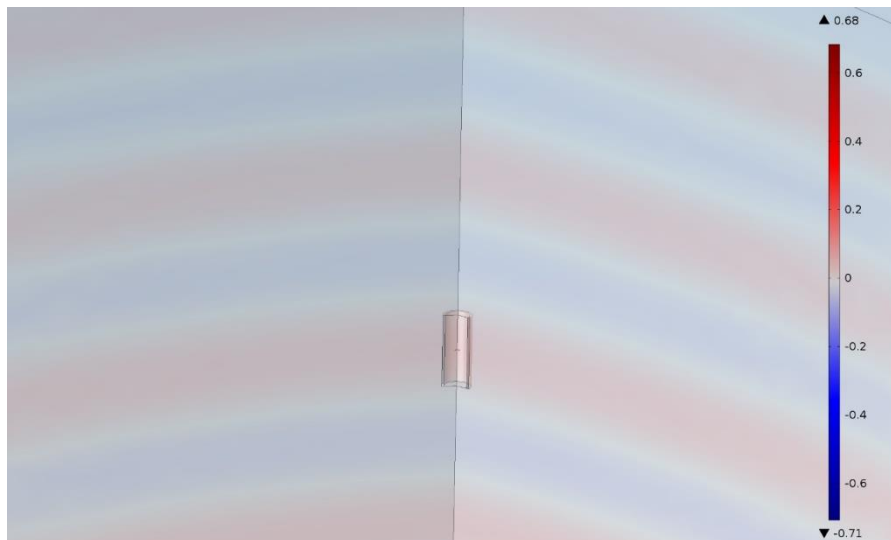

Figure 8b – FEM simulation of spherical free field with the presence of a small hollow cylinder. The real part of the pressure is shown as obtained at 4500 Hz.

Finally, the FEM $Z_{0_{sph}}$ is calculated for both the case without and with the small cylinder. Results are depicted in Figure 9 and show a small but clear effect on all the considered frequency range. At even higher frequencies resonances due to the physical size of the cylinder start to appear, but here are not studied. The evaluation is qualitative and shows an overall effect within 10% of the measured value: further studies can confirm a similar expected effect on actual measurements.

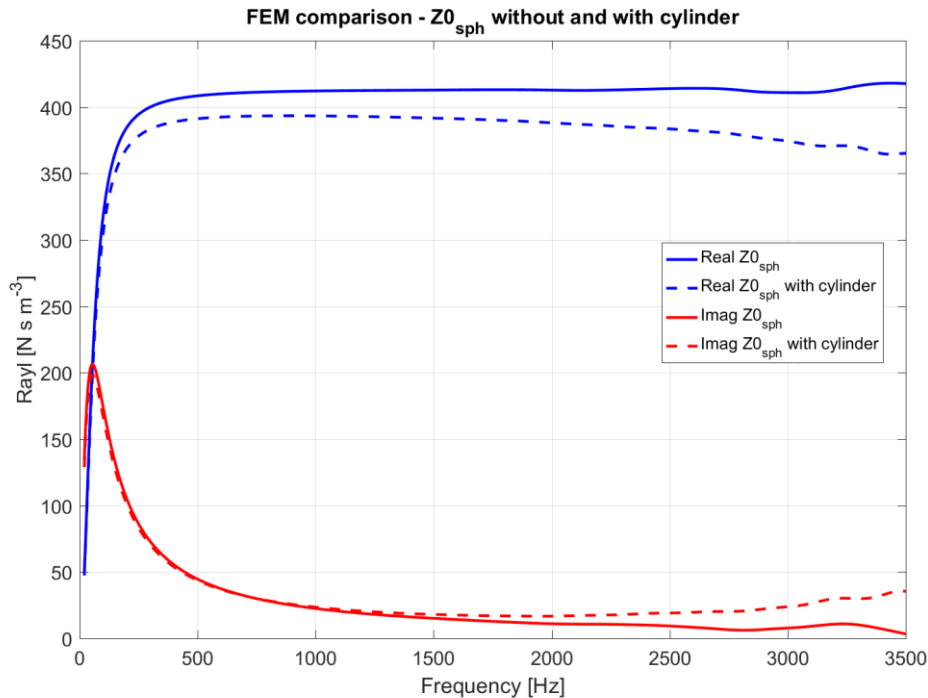

Figure 9 – FEM simulation of spherical free field acoustic impedance without and with the presence of a small hollow cylinder.

The future step will be to perform further simulations, still under the spherical wave regime, aimed to study critical aspects of the calibration and measuring technique. In particular, the study of the effects of the amplification horn under different conditions can be tested within the FEM environment and compared to the experimental results.

4. CONCLUSIONS

The paper reported the first phases of an application of the experimental method to measure sound absorption previously presented in 2014. The method is derived from the Adrienne one in order to overcome its weakness while intended to be usable over a mobile laboratory. The in-situ acoustical absorption coefficient measurement system is implemented on a vehicle and is based on pressure-velocity probe (p-u probe), in development inside the NEREiDE LIFE project.

The calibration phase has been performed acquiring sound absorption data of various layer of foam rubber with both the Adrienne method and a modified Adrienne method with a p-u probe. The results showed that at present, with a spherical signal, is not easy to use the suggested horn that amplify speed measurements. At the same time, measurements without the horn were in accordance with expectations, backed up by FEM simulations.

Future developments will improve the study with the horn, as well as a new methodology based on Kundt tube will be used for calibrate the system.

5. ACKNOWLEDGEMENTS

The authors thank the Tuscany Region for research grants financed for 50% with the resources of the POR FSE 2014-2020, falling within the scope of Giovanisì (www.giovanisi.it), the project of the Tuscany Region for the autonomy of young people.

6. REFERENCES

1. European Commission. Report from the Commission to the European Parliament and the Council on the Implementation of the Environmental Noise Directive in accordance with Article 11 of Directive 2002/49/EC. COM/2017/015. (2017)
2. Skrzypek, M., Kowalska, M., Czech, E. M., Niewiadomska, E., & Zejda, J. E. Impact of road traffic noise on sleep disturbances and attention disorders amongst school children living in Upper Silesian Industrial Zone, Poland. *International journal of occupational medicine and environmental health*, 30(3), 511. (2017).
3. Lercher, P., Evans, G. W., & Meis, M. Ambient noise and cognitive processes among primary schoolchildren. *Environment and Behavior*, 35(6), 725-735. (2003).
4. van Kempen, E., Casas, M., Pershagen, G., & Foraster, M. WHO environmental noise guidelines for the European Region: a systematic review on environmental noise and cardiovascular and metabolic effects: a summary. *International journal of environmental research and public health*, 15(2), 379. (2018)
5. Guski, R., Schreckenberg, D., & Schuemer, R. WHO environmental noise guidelines for the European region: A systematic review on environmental noise and annoyance. *International journal of environmental research and public health*, 14(12), 1539. (2017).
6. Licitra, G., Ascari, E., & Fredianelli, L. Prioritizing Process in Action Plans: a Review of Approaches. *Current Pollution Reports*, 3(2), 151-161. (2017).
7. Sandberg, U. and Ejsmont, J. Tyre/road noise reference book, INFORMEX, Kisa, Sweden. (2002).
8. Kuijpers, A., & Van Blokland, G. Tyre/road noise models in the last two decades: a critical evaluation. In *Proceedings of INTER-NOISE and NOISE-CON Congress and Conference No. 2*, 2494-2499. Institute of Noise Control Engineering. (2001).
9. Morgan, P. A., Phillips, S. M.; Watts, G. R. The localisation, quantification and propagation of noise from a rolling tyre. TRL Limited. (2007).
10. Licitra, G., Moro, A., Teti, L., Del Pizzo, A., & Bianco, F. Modelling of acoustic ageing of rubberized pavements. *Applied Acoustics*, 146, 237-245. (2019).
11. Licitra, G., Cerchiai, M., Teti, L., Ascari, E., & Fredianelli, L. Durability and variability of the acoustical performance of rubberized road surfaces. *Applied Acoustics*, 94, 20-28. (2015).
12. Licitra, G., Teti, L., Cerchiai, M., & Bianco, F. The influence of tyres on the use of the CPX method for evaluating the effectiveness of a noise mitigation action based on low-noise road surfaces. *Transportation Research Part D: Transport and Environment*, 55, 217-226. (2017).
13. EN ISO 10534-1, Determination of sound absorption coefficient and impedance in impedance tubes Part 1: Method using standing wave ratio, (2001).
14. ISO 13472-1, Acoustics Measurement of sound absorption properties of road surfaces in situ Part 1: Extended surface method, (2002).
15. Lo Castro, F., Iarossi, S., De Luca, M., Ascari, E., Stanzial, D., Licitra, G. On site determination of sound absorption coefficient of road pavements using mobile laboratory. *Proceedings of ICSV 24 Conference*. (2017).
16. CEN/TS 1793-5, Road traffic noise reducing devices Test method for determining the acoustic performance Part 5: Intrinsic characteristics In situ values of sound reflection and airborne sound insulation, (2003).
17. Tijs, E. and de Bree, H.E., An in situ method to measure the acoustic absorption of roads whilst driving, *Proceeding of the 35th German Annual Conference on Acoustics NAG/DAGA 23-26 March 2009*, Rotterdam, Netherland. (2009).
18. Iwase T., Yoshihisa, K., Measuring Method of Sound Reflection and Absorption Characteristics Based on the Particle Velocity and its Applications to Measurements on Such as Drainage Pavement of Road Surface, *Proceeding of the 32nd International congress and exposition on noise control engineering*. (2003).
19. Yntema, D. R., Druyvesteyn, W. F., and Elwenspoek, M., A four particle velocity sensor device, *Journal of the Acoustical Society of America*, 119, 943-951. (2006).
20. H.-E. de Bree et al. The μ -flown: a novel device for measuring acoustic flows. *Sensors and Actuators A: Physical*, 54, 1-3 pp552-557 (1996).
21. Donskoy, D. M., & Cray, B. A. Acoustic particle velocity horns. *The Journal of the Acoustical Society of America*, 131(5), 3883-3890. (2012).